

The British Sundial Society

BULLETIN

BSS Bulletin 22(iv)



December 2010



VOLUME 22(iv)
December 2010

Front cover: The group photograph taken at the Newbury Meeting, 25 September 2010, possibly our last event at the Mary Hare School. Apologies to anyone who has been mis-identified!

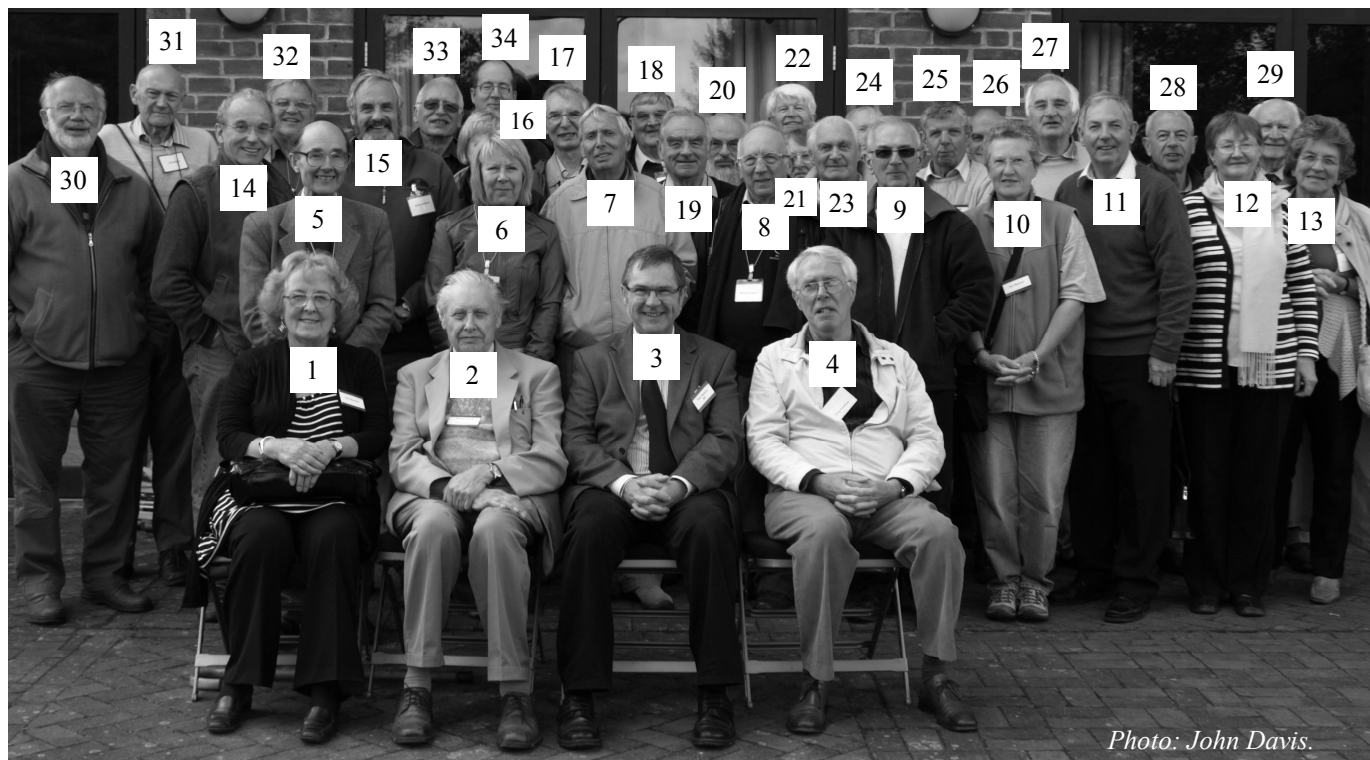

Photo: John Davis.

Front row (seated)

- 1 Vera Naumann
- 2 David Young
- 3 Peter Ransom
- 4 Doug Bateman

Second row

- 5 Frank King
- 6 Maureen Harmer
- 7 John Harmer
- 8 Mike Isaacs
- 9 Mike Shaw
- 10 Sue Manston
- 11 Geoff Parsons
- 12 Irene Brightmer
- 13 Pat Sedgwick

Third row

- 14 Kevin Karney
- 15 Martin Jenkins
- 16 Jean Hulbert
- 17 John Hulbert
- 18 Colin Davis
- 19 Tony Belk
- 20 Paul Riney
- 21 Wendy Turnham
- 22 Jim Quinn
- 23 Tony Wood
- 24 David Hindle
- 25 David Pawley
- 26 Dick Worley
- 27 Mike Lee
- 28 David Hawker
- 29 Michael Maltin

Fourth row

- 30 David Brown
- 31 Ian Butson
- 32 Mike Faraday
- 33 Mike Groom
- 34 Ian Maddocks

Not shown

- 35 Elspeth Hill
- 36 John Davis

Back cover: The Lyme Park (NT) dial. This is the replica device which won the Major Award in the 2010 BSS Sundial Design Competition, mounted on an 18th century pedestal. The original dial, now badly corroded and incomplete, was researched and redesigned by the winner, Graham Aldred, who made this replica with assistance from Tony Moss.

Photo: Graham Aldred.

BULLETIN

OF THE BRITISH SUNDIAL SOCIETY

ISDN 0958-4315

VOLUME 22(iv) - December 2010

CONTENTS

1. Editorial
2. The Equinoctial Armilla on the Façade of the Santa Maria Novella Basilica, Florence - *Simone Bartolini & Marco Pierozzi*
7. Readers' Letters - *Maes, Mills, Lowne*
9. A New Babylonian and Italian Hours Sundial for Selwyn College, Cambridge. Pt. 2. Numerical Insights - *Frank H. King*
11. Kratzer's Lost Dial - *JD*
12. Four Sundials in Adelaide, South Australia - *Douglas Bateman*
17. The Benares (India) Sundial in Three Dimensions - *John Ward, Margaret Folkard & Ron Blum*
20. A Very Large Polar Dial in Lalín, Galicia, N.W. Spain, Designed by José Luis Basanta Campos of Pontevedra - *Alan Smith*
22. The Construction of an Equatorial Sundial with a Reference to Anaximander's Skiatheron - *A. Galanakis, E. Theodossiou & V.N. Manimanis*
25. Postcard Potpourri 18: Lochgoilhead, Argyll - *Peter Ransom*
26. Meridies Media—An Historical Essay. The direct vertical noon mark mean time sundial at Greenwich - *Christopher Daniel*
31. Newbury 2010 - *Mike Groom*
33. The Perception of Time in Anglo-Saxon England - *David Scott*
37. Merton College Dial - *JD*
38. Beata Beatrix - *Roger Bowling*
41. New Dials (1) - *Valery Dmitriev*
42. The Evolution of English Mass & Scratch Dials c. 1250-1650. Pt. 2. Age Ranking Dials by Type - *Chris H.K. Williams*
44. New Dials (2) - *Brian Albinson*
45. The BSS 2010 Sundial Design Competition - *Tony Belk*

EDITORIAL

It has been suggested that *Bulletin* articles should be accompanied by a photograph of the author(s) so that readers who are not able to meet the writers at BSS events can get some idea of who is presenting the material. Other journals sometimes also carry a short description of the author, giving his/her affiliation and background. This is not an unreasonable suggestion and the Editor is minded to try it out, on the assumption that authors can provide suitable material and presuming there is not a chorus of disapproval from members.

This issue, as promised, we have reverted to our normal yellow covers. The blue used last time was well-received so we may use it again in the future. You will also notice that the 'Guidelines for Contributors' is missing from the inside front cover this time. It is still available from the

BSS website, or on request from the Editor, but it seemed an unnecessary use of space in every issue. Suggestions of what we should print there in future editions (in b&w only) are welcome, as are suggestions of any sort on the content of the *Bulletin*.

As this is the December issue, we once again include a Solar Data card for the coming year, with the calculations courtesy of Fiona Vincent.

The second part of the article by Jos Kint and Stan Ulens on methods of finding the eccentricity of the Earth's orbit using a sundial (Pt. 1 in the previous issue) has been delayed due to illness. It is planned to publish it in the next issue.

THE EQUINOCTIAL ARMILLA¹ ON THE FAÇADE OF THE SANTA MARIA NOVELLA BASILICA, FLORENCE

SIMONE BARTOLINI and MARCO PIEROZZI

ABSTRACT

The 'Equinoctial Armilla',¹ as described by Ptolemy in his *Almagest*, was built and placed on the Santa Maria Novella basilica in Florence in 1573 by the cosmographer Egnazio Danti with the purpose of determining the time of the Equinoxes and, consequently, the length of the Tropical year. He also aimed to give a meaningful contribution to the calendar reformation which the Grand Duke Cosimo was going to support. Looking at the history, the motivations and also the observations carried out with the Armilla, we try to compare the new speculations with those of Leonardo Ximenes to produce some novel conclusions concerning the length of the Tropical year as measured by Danti.

The Grand Duke Cosimo I de' Medici (1519-1574), being a great patron of the arts during the Renaissance, was also interested in the sciences, such as geography and astronomy, and in particular he was concerned with the reformation of the calendar. In this way his name would be remembered in history as in the Julian calendar of Julius Caesar. Danti supported the Grand

Duke's ambition and proposed to carry out a number of observations and related investigations which were necessary for this purpose. So, he had to measure with high precision the length of the Tropical year² and the time of the Equinox, as the Alexandrian astronomer Sosigenes had done at Julius Caesar's command.

In order to carry out such measurements, Danti proposed to Cosimo I that he place on the fine and harmonious façade of the Santa Maria Novella church two instruments, well known from the ancient times: an astronomical quadrant and an equinoctial armilla (Fig. 1).

The armilla was devised to determine with high precision the time of the Equinox and in particular the Spring Equinox, being related to the Easter time. This instrument is positioned on the western part of the façade and comprises two bronze rings, with a diameter of about 1.3 m, placed orthogonally with respect to each other and firmly secured to the wall (Fig. 2). On the upper part of the meridian ring we can see the engraved signature of Danti with the construction date (Fig. 3). One ring is positioned in the meridian plane while the other one is parallel to the equatorial plane (Fig. 4). The first ring was used to determine the exact time of solar noon, which divides the daytime into



Fig. 1. A drawing of the Equinoctial Armilla as described in the 'Primo volume dell'uso et fabbrica dell'astrolabio', page 317.

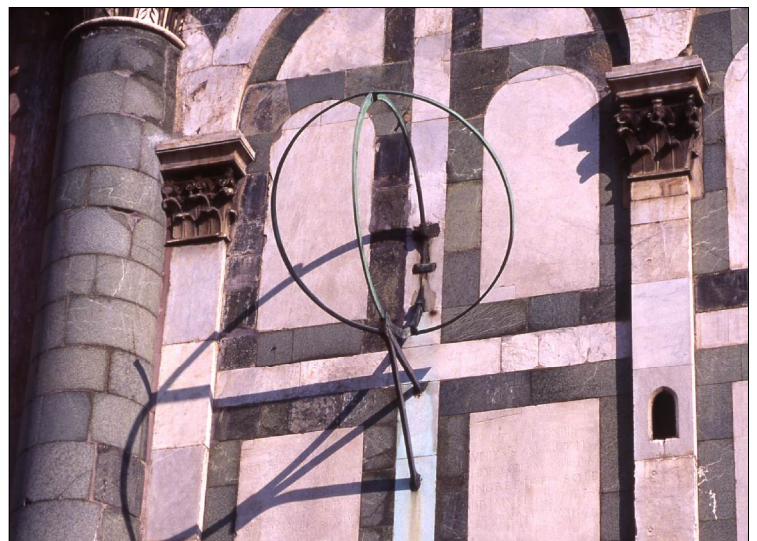

Fig. 2 (above). A photograph of the Equinoctial Armilla taken at 9:00 solar time on 21 March.

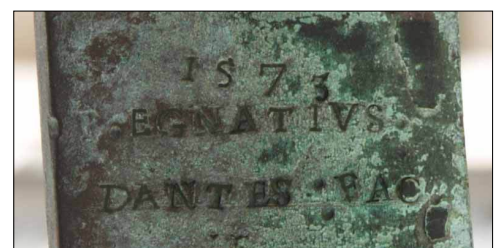

Fig. 3. Danti's signature and the Armilla construction date.

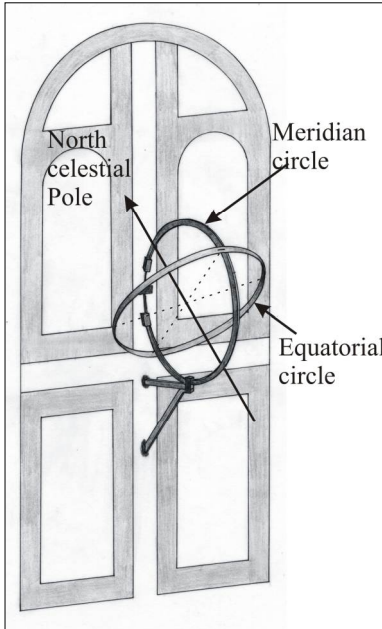
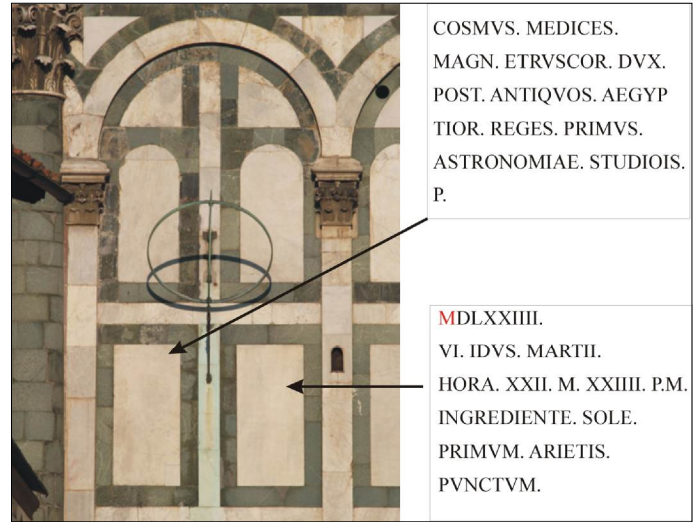

Fig. 4. The description of the parts constituting the Equinoctial Armilla.

Fig. 5. The details of the marble-engravings placed below the Armilla.



COSMVS. MEDICES.
MAGN. ETRVSCOR. DVX.
POST. ANTIQVOS. AEGYP
TIOR. REGES. PRIMVS.
ASTRONOMIAE. STUDIOIS.
P.

MDLXXIII.
VI. IDVS. MARTII.
HORA. XXII. M. XXIII. P.M.
INGREDIENTE. SOLE.
PRIMVM. ARIETIS.
PVNCTVM.

two equal parts with the Sun at its maximum height for that day.

At noon, the shadow of meridian ring on the wall is a thin straight line, while in the hours before or after noon it is a more or less elongated ellipse. The second ring was used to determine the time of the Equinox time (day and hour): at the Equinox the shadow of the Equinoctial ring lay on the concave part of the ring itself.

The armilla is a truly ancient instrument and it seems that it was used by Eratosthenes in the third century BC in Alexandria and also, subsequently, by Hipparchos (second century BC) in his researches and observations. For this reason one can find engravings celebrating Cosimo I as the successor of the ancient Alexandrian astronomical research. On its side, other engraving celebrates the measurement of the Equinox, the First Point of Aries, carried out on the 11th of March 1574 (Fig. 5).

Danti reports the whole text of the engravings in his *Primo volume* and, subsequently, describes how he made the measurements, going through all the steps, and also reporting the result of the second observation of the Equinox carried out on the 11th of March 1575 (Fig. 6). These dates

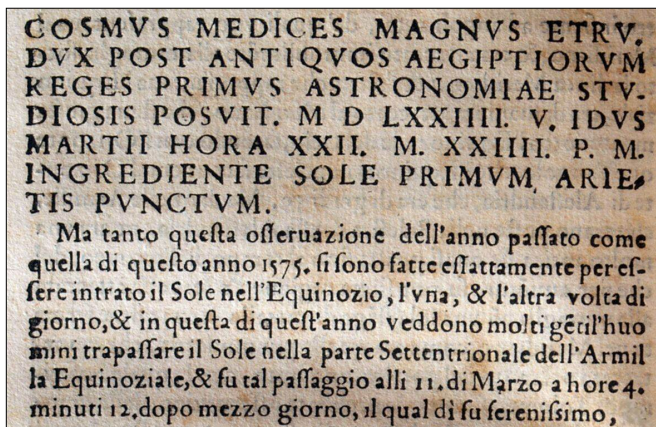

Fig. 6. The text from the Danti's treatise, *Primo volume*, page 320, where the Equinoctial measurement is described.

have caused discussion by some past astronomers and historians, because it is not clear if Danti is using the Common Style or the Florentine Style³ for the dating. According to Ximenes, Danti always wrote the dates in Florentine Style and, as a consequence, the first observation would be carried out in the year 1575 so that "Tra queste due iscrizioni dell'Armilla vi è una specie di contraddizione Cronologica. Poiché si sa, che Cosimo I morì l'anno 1574 il di 21 di Aprile, e l'osservazione dell'Equinozio fu fatta l'anno dopo, cioè il 1575, come si è detto"⁴ (*Concerning these two engravings of the Armilla a sort of chronological contradiction exists. Since, as everyone knows, Cosimo I died in the year 1574 on 21th of April and the Equinoctial observation was carried out the year after, i.e. the year 1575, as was said.*)

In order to explain this discrepancy, Ximenes claims that Danti installed the armilla and made the first engravings in the year 1574 following the Common Style. However, since it was not possible to observe the Equinox time because it was to happen at 2:00am, he made his first observation the year after when the event was to happen in the morning hours (the engravings give 22^h 24^m, according to the astronomical method of measuring time, corresponding to 10^h 24^m according to the northern European or French hours).

Hence, following Ximenes' reasoning, the second engravings were made during the period of the Grand Duke Francesco. In order to support his conclusions, Ximenes writes that if the observation was made in the year 1574 following the Common Style, the observation error would be enormous, because the Spring Equinox of that year happened at 2 hours 3 minutes after the midnight of the 11th day of March. That would imply a mistake of almost 8½ hours which cannot be charged to Danti, whose skill was renowned.⁵

According to Ximenes, the second observation was carried out in the month of March 1576, but Danti had moved to Bologna about 5 months previously and he wasn't certainly allowed to come back to carry out the measurement because his presence would not be tolerated by the Grand Duke Francesco who had driven him out. This second observation, carried out with the armilla on 11th of March at 4 hours

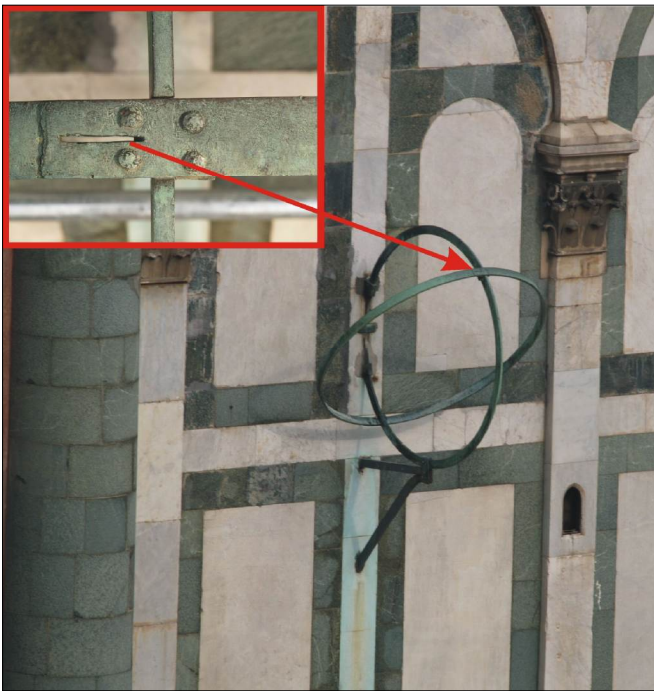

Fig. 7. The details of the slot carved in the convex part of the Equinoctial ring.



Fig. 8. Close-up of the swallow-tailed gnomon.

12 minutes after midday, was also performed with the occulus in the rose-window, as Danti himself reports in his declaration,⁶ but in the year 1574 Florentine Style (1575 Common Style).

According to the above considerations, it seems more likely that the Equinox observation dates are following the Common Style; in this way, the chronological sequence would be correct. On the other hand, the actual measurement carried out by Danti would be inaccurate. Such an error would be due to two causes. The first one is the latitude which is affected by an error⁷ of about 6' 30" and the other one comes from an unavoidable placement error of the armilla. An error of one arc-minute in latitude is equivalent to a one hour error in the determination of the Equinox,⁸ thus there is already an error of about 6 hours 30 minutes in the observation of the Equinox. The meridian circle is graduated with engraved lines every 10.5 mm; every interval is one degree, so that 1 mm is equivalent to 6 arc-minutes. Assuming that Danti positioned the armilla with

an error of half a millimeter – which would be a fine tolerance – the error in the Equinox determination would have been of 3 hours (0.5 mm on the armilla scale corresponds to 3 arc-min, i.e., 3 hours). Therefore, the total error of the Equinox determination would have been of 6.5 ± 3 hours. However, Danti didn't know the effect of the atmospheric refraction on the solar height. As a matter of fact, the Sun at the Equinox appears about 1' higher and such value should be subtracted with respect to the error due to the latitude, as pointed out by Ximenes,⁹ so the total error in the Danti's observation of the Equinox might be 5.5 ± 3 hours.

Ximenes reports the Equinox times for the years 1574 and 1575 (Common Style), computed according to the Cassinian Tables: they are both different from the corresponding ones measured by Danti, by an amount of about 8h 20m (Fig. 9), which is just the value of Danti's error. Thus, it seems likely that Danti could only have carried out the Equinox observations in the years 1574 and 1575 (Common Style).

Date		Equinox time		Difference hr:min
Common Style	Florentine Style	Cassinian tables	Danti's meas.	
1574	1573	2 ^h 03 ^m 22 ^s	10 ^h 24 ^m	8 ^h 21 ^m
1575	1574	7 ^h 52 ^m 11 ^s	16 ^h 12 ^m	8 ^h 20 ^m

Fig. 9. A comparison between the Danti's observations and the Equinox time as computed via the Cassinian Tables.

Such a measure, on the other hand, is certainly affected by the error due to the small size of the armilla. Danti became well aware of this problem just after his first measurements, so that he conceived the other project for the construction of a great dark room sundial inside the church. But, let us continue the description of the features of our armilla!

In the convex part of the equinoctial ring there is a small slot (Fig. 7). Since the Sun is not a point source of light, the shadow produced by the equatorial ring doesn't have the same thickness as the ring, so the shadow centred in the concave part should be considered. Danti, in order to make this critical observation phase better, managed to build a slot in the centre of the belt towards the Sun; when the light-trace produced by the slot was at the centre of the concave part, it was the Equinox.

Two small swallow-tailed gnomons were set on the meridian circle (Fig. 8), with the purpose of measuring the solar height at the Summer and Winter Solstices (Fig. 10), on the graduated arc engraved on the meridian ring (Fig. 11). Moreover, these gnomons should indicate the solstices through suitable lines carved on the marble of the façade. (Fig. 12). In reality, the gnomon for the Winter Solstice is broken and mis-positioned on the meridian circle (its distance from the equinoctial circle is 1 cm longer with respect to the correct one), maybe due to a preliminary tentative study to use the instrument, which was subsequently slightly modified. Looking carefully at the white marble behind the armilla, just the Capricorn, Libra and Aries signs

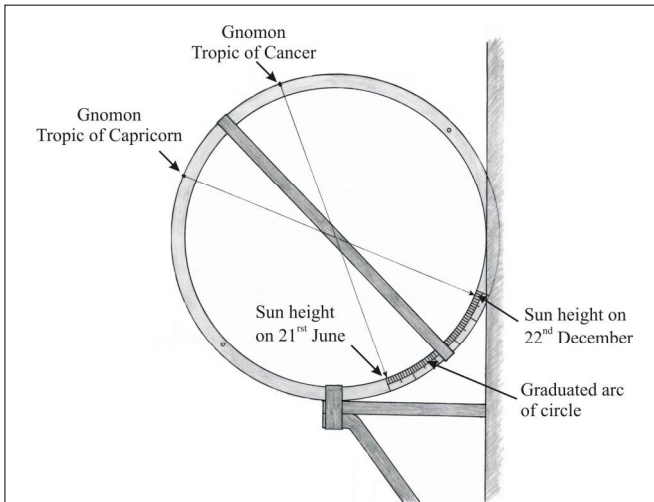

Fig. 10. The use of gnomons, in the meridian circle, to measure the Solar height at the Solstices.

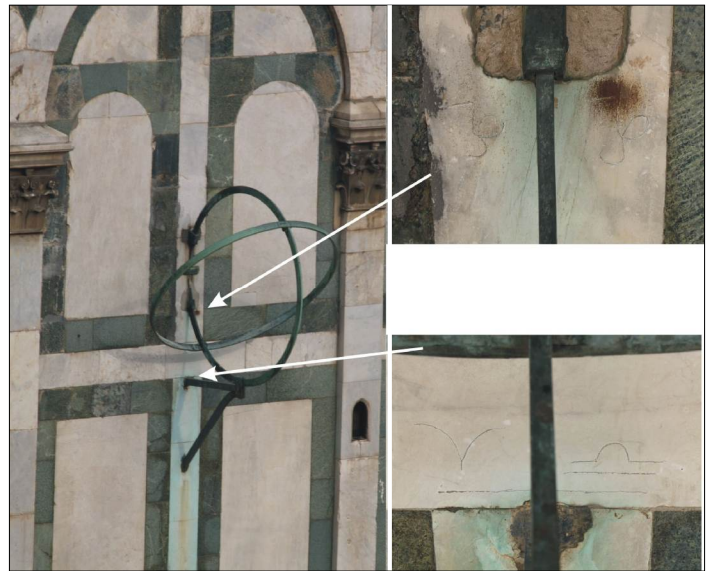

Fig. 13. The zodiac signs of Capricorn, Aries and Libra, highlighted by graphite powder, carved on the marble.



Fig. 11. Part of the graduation engraved on the meridian ring of the Armilla.

have been carved (Fig. 13): the work was unfinished work due to the death of Cosimo I.

The convex part of the equinoctial ring is so featured that it projects its shadow, at the Winter Solstice, on the brass plate securing the meridian circle to the wall (Fig. 14).

Two holes are present on the meridian circle, which are so placed that their ideal connecting line is orthogonal to the equinoctial ring plane and is inclined with respect to the equatorial plane by an angle equal to the latitude. In other words, this line is parallel to the Earth's polar axis (Fig. 15) and it was probably formed by a stretched brass wire between the two holes (a small piece of wire is still visible hanging from the upper hole). The use of the wire is not clear; such a device was generally used to indicate the hours through its shadow projected into the concave part of the equinoctial ring but, in this case, there are no hour graduations for the purpose.

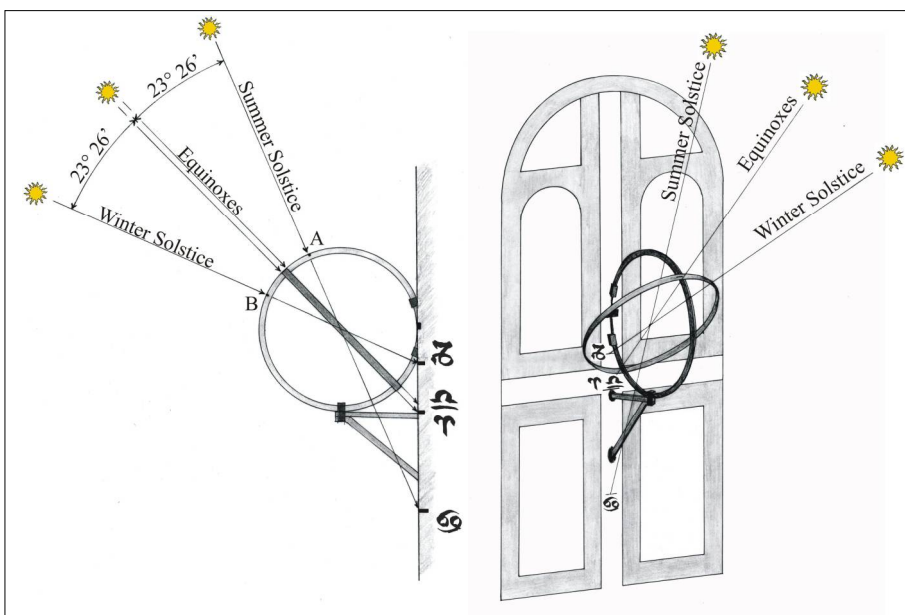

Fig. 12. The use of gnomons to indicate the astronomical time of the Solstices and Equinoxes.

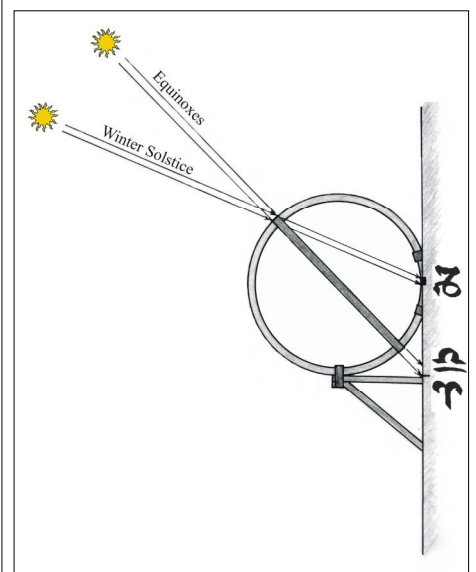

Fig. 14. The use of the upper part of the Equinoctial ring as an indicator for the Equinoxes and the Winter Solstice.

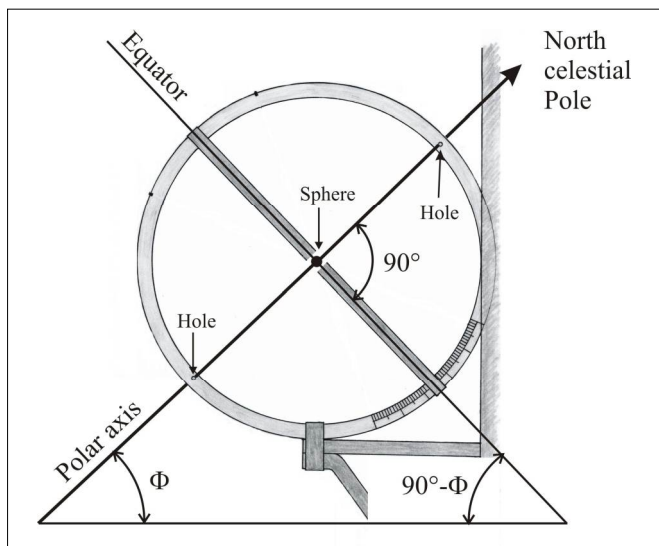

Fig. 15. The supposed position of the wire between the two holes, where Φ is the latitude of the site.

The Observation of the Equinox with the Armilla and the Measurement of the Tropical Year

The Equinox is observed when the Earth is in a particular position in space with respect to the Sun. Such an astronomical situation can happen at any hour of the day or the night, so that it will be possible to observe the Equinox time with the armilla only if the Sun illuminates it. This is one of the reasons, together with stability requirements, that Danti decided to secure his armilla on the church of Santa Maria Novella, in fact its façade is almost directly towards the south so it receives sunlight from sunrise to sunset on the days of the Equinox. That being stated, we know that Danti carried out two Equinox observations on this armilla: the first one at 22^h 24^m on 11 March 1574 and the other one at 4^h 12^m on 11 March 1575. These times are counted according to the astronomical method of measuring time, which places midday the beginning of the day; once transformed in northern European hours (as Danti would say), they are 10^h 24^m and 16^h 12^m, respectively.

As already stated, the time of the Equinox is when the shadow of the upper part of the armilla falls on the concave part of the ring; though the ring has the same dimensions in all its parts, its shadow projected on its lower part is smaller than the dimension of the ring itself because the apparent diameter of the Sun (32') is not negligible for the observations.

When the centre of the Sun is on the equatorial plane (the Equinox), its upper edge is about 16' higher, while its lower edge is similarly about 16' lower. In such case, two thin slivers of light will be visible in the upper and lower concave parts of the ring. The width of such bands of light will be about 6 mm, so that the projected shadow dimension will be $48 - 12 = 36$ mm (Fig. 16).

In order to achieve a better precision in the measurement of the year, it is necessary to perform a comparison between observations carried out over a long time span. Such a procedure allows for the unavoidable lack of observation

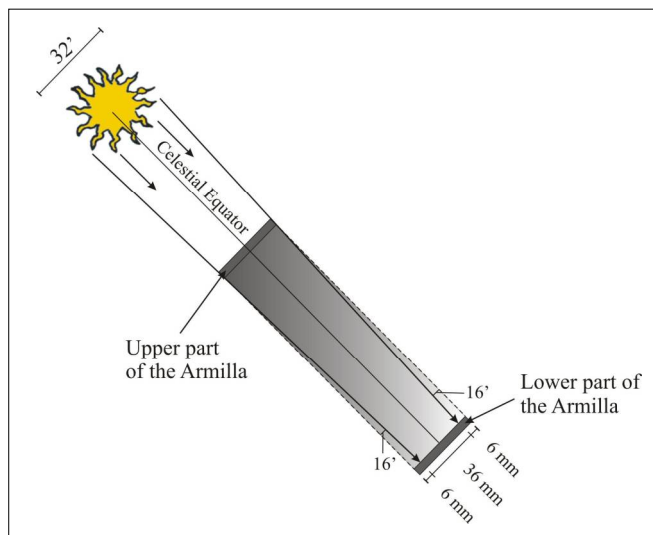

Fig. 16. The Sun on the celestial Equator at the Equinox and the shadow produced by the upper part of the ring.

accuracy due to the approximate knowledge of the latitude value of the armilla site, and consequently to the inclination error of the armilla itself with respect to the horizontal. Thus, in order to compute the length of the tropical year, Danti considered the earlier observation carried by Ptolemy in the year 463 after the death of Alexander, the seventh day of the month of Pachon, about 1 hour after midday (corresponding to 13 hours of 22nd of March in 140 AD).¹⁰

Taking into account the number of days and hours from then to the Equinoctial observation carried out at 11^h 40^m of 11th of March 1574,¹¹ we get 523757.944 days ($359 \times 366 + 1075 \times 365 - 11.0555$), which we divide by the integer number of Sun revolutions about the Earth, i.e. 1434 Julian years. Thus we obtain the length of the year as 365.242639 days, ($365^d 5^h 49^m 24^s$), i.e. about 12^s longer than the value adopted by the Gregorian Reform: a very good result considering the small size of the armilla.

REFERENCES AND NOTES

1. The Latin word 'armilla' originally meant a ring or a circle which Roman soldiers had on their arm or, more commonly, an ornamental armband. It is the basis of the English term 'armillary sphere' meaning a model of the celestial globe constructed from a series of rings.
2. The tropical year is the time interval (days, hours, minutes, ...) between two successive Spring equinoxes.
3. The Florentine Style assumes, as the beginning of the year, the date 25th of March while the Common Style assumes the date 1st of January.
4. L. Ximenes: *Del vecchio e nuovo gnomone fiorentino*, Firenze, Stamperia Imperiale, p. LII (1757).
5. L. Ximenes: *Del vecchio e nuovo gnomone fiorentino*, Firenze, Stamperia Imperiale, pp. LII-LIII (1757).
6. L. Ximenes: *Del vecchio e nuovo gnomone fiorentino*, Firenze, Stamperia Imperiale, p. LIV (1757).
7. S. Bartolini: *Gli strumenti astronomici di Egnazio Danti e la misura del tempo in Santa Maria Novella*, Firenze, Edizioni Polistampa, Collana Testi e Studi, p.38 (2008).
8. J.L. Heilbron: *Il Sole nella Chiesa* - Bologna, Editrice Compositori, p. 84 (2005).
9. L. Ximenes: *Del vecchio e nuovo gnomone fiorentino* - Firenze, Stamperia Imperiale, p. LV (1757).

10. G.J. Toomer: *Ptolemy's Almagest*, New York Berlin Heidelberg Tokyo, Springer-Verlag, p. 138 (1984).
11. The observation time has been increased by $1^{\text{h}} 16^{\text{m}}$ (the longitude difference between Florence and Alexandria in Egypt, expressed in time units) in order to make possible a comparison with the observation carried out in Alexandria.

Simone Bartolini, Italian Military Geographic Institute, Florence.

simo.bartolini@tiscali.it

Marco Pierozzi, Italian Navy Hydrographic Institute, Genova.

pierozzi@tele2.it

READERS' LETTERS

Windvane Dials

In their article *An obelisk-shaped sundial with wind indicator in the Mainfränkisches Museum Würzburg, Germany* in the June *Bulletin*, Van der Wall and Wagner speculate that this remarkable monument is "quite unique on the continent if not worldwide".

Three years ago I visited a similar, although more ornate monument in the *Stadtgarten* (municipal garden) in Schwäbisch Gmünd. This town, latitude 48.8° , is located some 110 km (indeed, 1.0°) south of Wiesentheid, where the Würzburg sundial was suggested to come from.

The obelisk (ca. 70 cm high, base edge 25 cm) has reclining N, S, E and W dials. The centre cube (30 cm edge) has vertical N, E and W dials. The south face has a portrait of a man holding a staff and a bottle behind a glass window.



The lower block (57 cm high, 50×63 cm wide) has on its N face also a vertical dial, whereas the S face has a multitude: a split vertical S and a split horizontal dial, a flat and two cylindrical polar dials, and a split equatorial winter dial. The block has windroses on E and W faces, each with 32 labeled divisions. The hands are missing but there should be a connection to the gilded windvane on top, which depicts a triumphator in a four-in-hand chariot. The three-sided pedestal (140 cm high) consists of two pieces, apparently joined later on. In the upper centre is a stone ball and a shape protruding to the southeast.

According to the plaque at its base, the monument was made in 1770. It should stem from the circle of Johann Michael Keller and was earlier located in the pleasure garden of Georg Franz von Stahl, nobleman from Pfeilhalden. The monument was restored in 1993. On the internet, I found that Keller was the town's architect from 1753-1792, that Pfeilhalden is a nearby hamlet, and that Stahl was mayor of Schwäbisch Gmünd from 1786-1797.

The sundial has been recorded in the database of the Sundial Working Group of the German Society of Chronometry (DGC) as nr. 503. (Quite an oldie; present numbers are in the 14,000s!) According to the database, the sundial was made by Stegmaier (sculptor at the cathedral) and the present monument is an exact copy of the badly weathered original.

So the tentative conclusion is that the Wiesentheid sundial, which presumably dates from 1742, was exceptional enough to be well-known in the region. And that Stahl, who spent much energy (and money) embellishing his baroque garden, ordered Stegmaier in 1770 to use that design as a source of inspiration for his own sundial.

*Frans Maes
Netherlands*

Haidinger's Brush (1)

In the September issue of the *Bulletin*, Roger Bowling asks if anyone has seen the optical phenomenon known as 'Haidinger's brush' when looking at the blue sky. It appears as a very faint, fuzzy, figure-eight shaped yellowish brush crossed with a bluish brush,¹⁻³ and seems to be due to a lack of symmetry ('anisotropy') in certain visual pigments found in the retina of the human eye. This anisotropy results in colouration when linearly polarized light – such as is present in light from the blue sky – falls upon the retina, particularly its most sensitive region known as the *fovea*.

Being of very low intensity (or it would constitute a nuisance in normal vision!) two factors are required to see the phenomenon. The first is practice; the second is a strong source of polarized light. Both requirements are achieved by obtaining polarizing sunglasses or a 2" square of Polaroid.⁴ Hold one lens of the sunglasses, or the piece of Polaroid, in front of the dominant eye and look fixedly at a strongly illuminated surface such as a cloud or piece of white paper. Rotate the polarizer slowly back-and-forth in the hand. Haidinger's brush will usually appear at the centre of the visual field within 20 seconds or so, but can then disconcertingly disappear again! Rest the eye, or direct the gaze to another part of the visual field.

When the brush can be reliably discerned in this 'augmented' manner it is time to attempt to see it in the naturally polarized light of the blue sky. The percentage of linear polarization varies with clarity and position,⁵ and rarely exceeds 50% in the UK.⁶ Choose a clear blue sky, and fix the gaze on a region about 90° from the Sun. A point near the zenith an hour or so before sunset is said to be particularly favourable. Again, it may take a little while for Haidinger's brush to appear. Minnaert¹ says the phenomenon can be seen still more clearly in the reflection of the sky in a spherical glass globe.⁷

Modern TV and computer screens are strongly polarized – check with your piece of Polaroid – so it may be possible to discern the brushes if you stare at a blank (blue?) screen for a while. However, don't practise too hard, or Herr Haidinger might emerge to spoil your normal view of programmes!

1. M. Minnaert: *The Nature of Light and Colour in the Open Air*, Dover, (1954), pp.254-257. Later editions and variations have been published.
2. G.P. Können: *Polarized Light in Nature*, CUP (1985).
3. See 'Haidinger's brush' in *Wikipedia*.
4. A piece 100 mm × 50 mm is obtainable from www.sciencestore.co.uk
5. A. Mills: 'The Sellotape Sundial', *BSS Bulletin*, 98.1, pp.3-9 (1998).
6. A. Mills: 'An Electronic Polarization Sundial and Photometer', *BSS Bulletin*, 21(i), pp.14-16 (March 2009).
7. www.otherwisetrading.co.uk. 60 mm diameter is the minimum size useful in this application. 80 mm is better.

Allan Mills
Leicestershire

Haidinger's Brush (2)

In the September *Bulletin* Roger Bowling asks if anyone has seen Haidinger's brush. My answer is a decided 'Yes, on numerous occasions', although admittedly not recently with aging eyes. The brush was first described by the German physicist Wilhelm von Haidinger in 1844. The contrast is low against the background and not everyone can see it, but as generally reported it takes the form of a pale yellow bar with blue elongated patches on either side, covering an area of about 3 to 5 degrees in diameter, the approximate size of a thumbnail at arm's length. Both yellow and blue spread and fade towards their outer parts giving a resemblance to brushes. Some observers see the blue as continuous, not the yellow. As Roger suggests, it is caused by polarised light.

The internet Wikipedia entry 'Haidinger brush' has a coloured sketch of the most common appearance and gives a detailed explanation of the mechanism. Briefly, it is due to the optical properties of the pigments and fine structure of the retina and the response to the polarisation of incoming light.

To see the brush try looking at a brightly-illuminated white paper through a polarising filter. Polarising sunglasses will do, provided they are not colour tinted. If the polariser is turned in its own plane, the pattern will also rotate which may help to identify it. The light from a computer LCD monitor is polarised diagonally and a white screen could provide a suitable source without need for a filter. The brush may take a minute or two to detect, but patience will often be rewarded. Once recognised, it will be easy to see on subsequent occasions. In nature, it can be seen without a filter by taking advantage of the fact that sky-light is partially polarised with the maximum effect at 90 degrees from the sun. The most favourable conditions occur near sunset, looking upwards towards the zenith in a cloudless sky. It will be noted that the yellow bar points towards the sun with the blue patches perpendicular to that direction. The orientation of the blue thus indicates the plane of vibration of the polarised light.

It is remarkable that polarisation can be detected by the eye alone in this way!

Michael Lowne
East Sussex

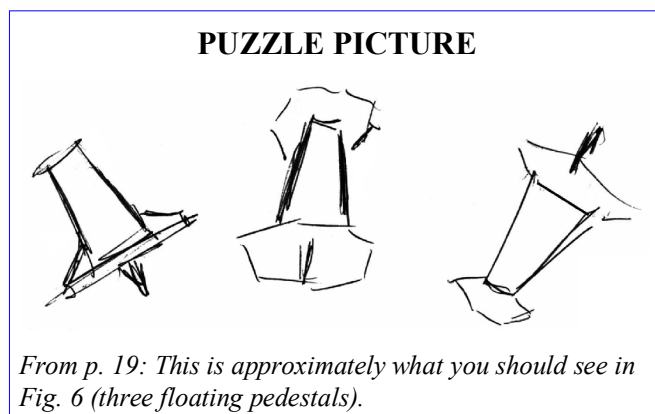

A NEW BABYLONIAN AND ITALIAN HOURS SUNDIAL FOR SELWYN COLLEGE, CAMBRIDGE

Part 2. Numerical Insights

FRANK H. KING

The design and construction of the new sundial at Selwyn College were described in Part 1 which was published in the September issue of the *BSS Bulletin*.¹ In Part 2, some interesting numerical properties are investigated.



Fig. 1. 19h Italian hours on the day of the summer solstice.

The Criss-Cross Pattern

At first sight, the most-immediate difference between a conventional sundial (one with a polar-oriented gnomon) and a dial which shows Babylonian and Italian hours is that instead of the familiar fan-shaped array of hour-lines there is a criss-cross pattern. See Fig. 1.

The pattern which is formed by the intersection of the two families of hour-lines has some interesting and easy-to-understand numerical properties.

Consider what happens at an equinox when there are 12 hours of day and 12 hours of night. Expressed in French hours (normal local sun time), sunrise is at 6h and sunset is at 18h. Expressed in Babylonian hours, sunrise is at 0h and, expressed in Italian hours, sunrise is at 12h because it is 12 hours since sunset.

Let's represent these three sunrise times as:

$$F = 6 \quad B = 0 \quad I = 12$$

where F refers to French hours, B refers to Babylonian hours and I refers to Italian hours. Babylonian hours are six hours behind French hours and Italian hours are six hours ahead of French hours. These differences can be expressed as:

$$B = F - 6 \quad \text{and} \quad I = F + 6$$

At noon, when $F = 12$, it is clear that $B = 6$ and $I = 18$.

Whenever F is an integer, B and I are also integers so Babylonian and Italian hour-lines intersect at hourly intervals along the equinoctial line, in particular at $F = 12$ where the noon line contributes to the intersection.

During the summer months, the days are longer than 12 hours. There is extra daylight before 6h and extra daylight after 18h (both times being French hours). Let d be the number of extra hours of daylight, at each end of the day. The relationships become:

$$B = F - 6 + d \quad \text{and} \quad I = F + 6 - d$$

Now at noon, when $F = 12$, the Babylonian hours time is later than 6h by an amount d , because the sun is rising d hours earlier than at an equinox. Likewise, the Italian hours time is earlier than 18h by an amount d because the sun is setting d hours later. Note that the relationships are also valid in winter but d is then negative.

Summing the two left-hand sides and the two right-hand sides gives:

$$B + I = 2F$$

This explains why the time in French hours is the average of the times in Babylonian and Italian hours: $F = (B + I)/2$.

Instead of summing, one can subtract:

$$B - I = -12 + 2d$$

Now add 24 to each side and rearrange:

$$B - I + 24 = 12 + 2d \quad \text{so} \quad B + (24 - I) = D \quad \text{or} \\ B + C = D$$

where C refers to Co-Italian hours, $(24 - I)$, and D refers to the length of the day from sunrise to sunset. This is 12 hours plus two lots of extra daylight d . It is self-evident that $B + C$ (the time since sunrise plus the time until sunset) is D (the length of the day).

The relationship $B + (24 - I) = D$ is important. If any two of the three variables is an integer then the third is also an integer. In particular, if the number of hours of daylight D is an integer then whenever either B or I is an integer the other must also be an integer.

Accordingly, when D is an integer, the shadow of the nodus runs through a sequence of crossing-points and it is possible to read French hours almost directly. One simply counts how many crossing-points remain to be traversed before noon (or how many have been traversed since noon).

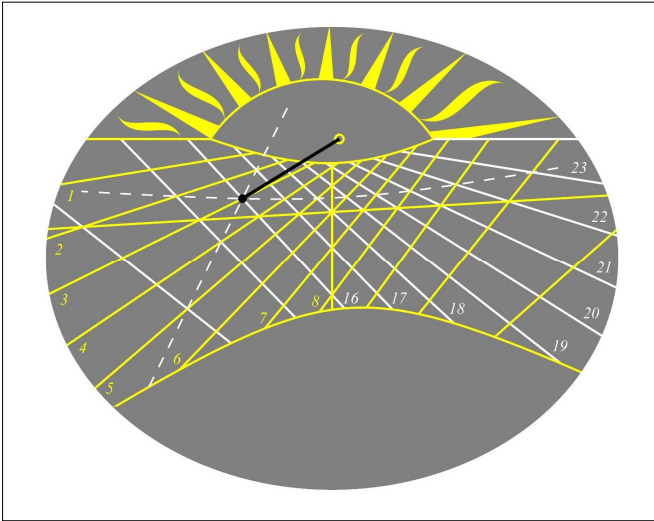

Fig. 2. 3h Babylonian hours, 16h Italian hours and 9.5h French hours.

In Fig. 2 it is immediately clear that the time is 2½ hours before noon. It is hardly necessary to evaluate $(3 + 16)/2$ and convert the result, 9½, into the time 09:30.

The extra daylight d depends on the latitude ϕ and solar declination δ . These three entities are related by:

$$\sin d = \tan \phi \tan \delta$$

Here d is expressed as an hour-angle so, to determine the declination required for the length of the day to be 11 hours, one sets $d = -7.5^\circ$. This takes 7.5° off each end of a 12-hour day, a total of 15° , which corresponds to one hour.

Taking the latitude of Selwyn College as $52^\circ 12' 3''$:

$$\tan \delta = \frac{\sin d}{\tan \phi} = \frac{\sin(-7.5^\circ)}{\tan(52^\circ 12' 3'')} = -0.1012$$

Accordingly, $\delta = -5.78^\circ$. This is the declination of the constant-declination curve drawn as a broken line in Fig. 2.

In Cambridge, the length of the day, D , varies from fewer than 8 hours to more than 16 hours. There are therefore nine possible integer values of D and, in each case, the associated constant-declination curve runs through a sequence of crossing-points. In the example just given, the length of the day is 11 hours and the declination is -5.78° .

Using Hour-Angles and Declinations for Setting out

The nine declinations whose associated constant-declination curves run through sequences of crossing-points are given in the table shown as Fig. 3.

The nine integer lengths of day, D , range from 8 to 16. For each, d is the amount of extra daylight (relative to a 12-hour equinoctial day) at each end of the day, so $d = (D - 12)/2$. For each d , the associated declination δ is determined as just illustrated.

Anyone wishing to see the shadow of the nodus running through a sequence of crossing-points should arrange to visit on a day when the solar declination is one of the values in the table. There are 18 such occasions each year.

D , hours	d , hours	δ , °
8	-2.0	-21.20
9	-1.5	-16.53
10	-1.0	-11.35
11	-0.5	-5.78
12	0.0	0.00
13	0.5	5.78
14	1.0	11.35
15	1.5	16.53
16	2.0	21.20

Fig. 3. Nine special declinations.

Note that the table applies to Cambridge. At a different latitude the values of δ will be different and there may be more or fewer entries. On the equator, there would be just a single entry since $D = 12$ every day of the year. Babylonian, Italian and French hour-lines coincide, though they are labelled differently. On the Arctic and Antarctic Circles there would be 25 entries since D can range from 0 to 24.

The special declinations give rise to one possible method of setting out Babylonian and Italian hour-lines. The scheme is illustrated in Fig. 4.

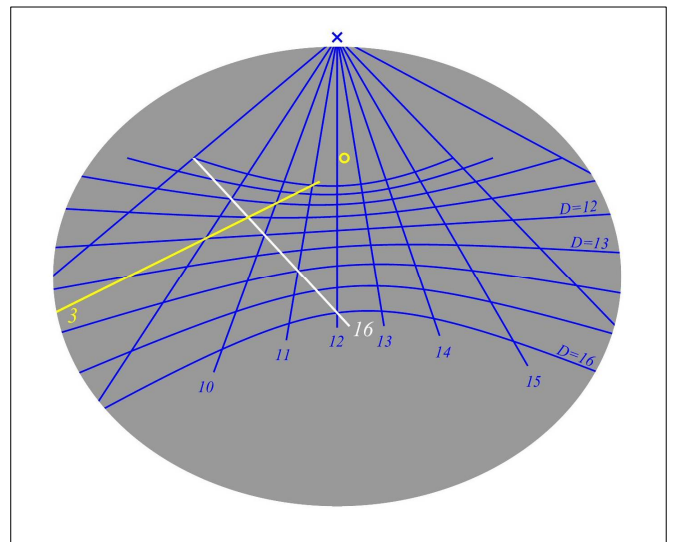

Fig. 4. Setting out Babylonian and Italian hour-lines.

The procedure begins by choosing a sub-nodus point and a nodus height. As in Fig. 2, the sub-nodus point is shown as a yellow circle. The next step is to determine where a hypothetical polar-oriented style through the nodus would intersect the dial. This root-of-the-gnomon point is shown as a blue cross which is just off the top of the slate. The line from the cross to the circle is the sub-style.

Next, draw a set of French hour-lines radiating from the root of the gnomon. The hour-lines from 8h to 17h are shown in the figure but only those from 10h to 15h are labelled.

Then, draw the constant-declination curves for the nine special declinations given in Fig. 3. All nine constant-declination curves are shown in the figure but only those for $D = 12, 13$ and 16 are labelled.

The French hour-lines and the constant-declination curves, both shown in blue, form a coordinate system which provides a means of plotting points in terms of their hour-angles and declinations. The only novelty is that the constant-declination curves are identified by their associated D -values rather than by their declinations.

Every Babylonian and Italian hour-line runs through a set of crossing-points and two sample lines are shown, 3h Babylonian and 16h Italian. The Babylonian hour-line passes through three intersection points and the Italian hour-line passes through five.

From the relationships given above it is easy to derive two more:

$$D = 2(12 + B - F) \text{ and } D = 2(12 - I + F)$$

To plot the 3h Babylonian hour-line, use the left-hand relationship and set $B = 3$ giving $D = 2(15 - F)$. From this, tabulate a set of (F, D) pairs as (9,12), (10,10) and (11,8). Identify these intersections and join them up.

To plot the 16h Italian hour-line, use the right-hand relationship and set $I = 16$ giving $D = 2(F - 4)$. From this, tabulate a set of (F, D) pairs as (8,8), (9,10), (10,12), (11,14) and (12,16). Identify these intersections and join them up.

The two hour-lines intersect at 9½h French hours or 09:30. This point of intersection is where the shadow of the nodus falls in Fig. 2. There is a case for marking in French half-hour lines but they are omitted from Fig. 4 to reduce clutter.

The winter and summer solstice curves have not been drawn but they are just as on any sundial which has these features.

In summary: anyone who can set out ordinary hour-lines and constant-declination curves can readily set out Babylonian hour-lines and Italian hour-lines. Note that the method described applies to a dial of arbitrary orientation and there is not even a requirement for it to have a plane surface.

The Horizon Line

Although unlabelled, the 0h Babylonian hour-line and the 24h Italian hour-line both feature on the Selwyn College dial. These lines coincide with projections of parts of the eastern and western horizon respectively.

The noted Italian *gnomonista*, Gianni Ferrari, has pointed out² that, since any straight line can be specified by two points, it is unnecessary to draw all the constant-declination curves in Fig. 4. All that is required is to note where the French hour-lines (and half-hour lines) intersect the equinoctial line and the horizon line.

To plot the 16h Italian hour-line, note where the $F = 10$ line intersects the equinoctial line and where the $F = 8$ line intersects the horizon line. The $F = 10$ stems from the relationship $F = I - 6$ which applies at the equinoxes. The $F = 8$ stems from the relationship $F = (B + I)/2$ given that on the horizon line $B = 0$.

To plot the 3h Babylonian hour-line, note where the $F = 9$ line intersects the equinoctial line and where the $F = 13\frac{1}{2}$ line intersects the horizon line. The $F = 9$ stems from the relationship $F = B + 6$ which applies at the equinoxes. The $F = 13\frac{1}{2}$ stems from the relationship $F = (B + I)/2$, given that on the horizon line $I = 24$.

Gianni Ferrari also explained how this method has to be adapted slightly for horizontal dials where the horizon line is at infinity...

The 16h Italian hour-line again intersects the equinoctial line at $F = 10$ and, in some sense, again intersects the horizon line at $F = 8$ but, since the horizon line is at infinity, this requires the hour-line to be drawn parallel to the $F = 8$ line.

The 3h Babylonian hour-line again intersects the equinoctial line at $F = 9$ and, in some sense, again intersects the horizon line at $F = 13\frac{1}{2}$ which requires the hour-line to be drawn parallel to the $F = 13\frac{1}{2}$ line.

These procedures are theoretically sound but have limitations in practice. The relevant intersection points may be off the dial. At Selwyn College, the 11h Babylonian hour-line intersects both the equinoctial line and the horizon line off the dial.

It has already been noted that the French hour-lines radiate from a point which is also off the dial. In practice, the coordinates of several points on each hour-line were computed and marked on the slate. These points included intersections with the winter and summer solstice curves where appropriate.

REFERENCES

1. F.H. King: 'A New Babylonian and Italian Hours Sundial, Selwyn College, Cambridge', *BSS Bull*, 22(iii), pp. 2-8, (Sept 2010).
2. G. Ferrari: Email sent to the Sundial Mailing List 30 March 2010, <http://www.mail-archive.com/sundial@uni-koeln.de/msg15448.html>.

Author's address:
Frank.King@cl.cam.ac.uk

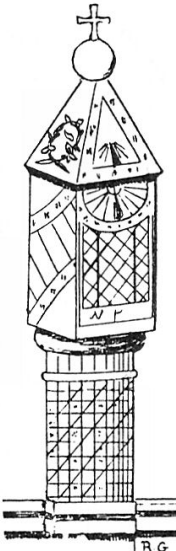

Kratzer's Lost Dial

Now lost, this is the 1520 dial designed by Nicolaus Kratzer for the churchyard wall of St Mary's church, Oxford.

The dial was described by Kratzer in his MS *De Horologiis* (now in the Bodleian Library). The stone cutting was performed by William East.

The description says that it showed Babylonian hours with green lines on the East side and Italian hours in blue on the West, with ordinary hours and declinations on the south face.

This sketch is from Robert Gunther's *Early Science in Oxford*, Vol. II, and is based on Loggan's 17th-century engraving but it seems to show a different scheme.

JD

FOUR SUNDIALS IN ADELAIDE, SOUTH AUSTRALIA

DOUGLAS BATEMAN

There are many fine dials in Australia as exemplified in my recent report on the work of Sundials Australia.¹ During my stay in Adelaide I was fortunate to see a number of dials, and have selected four worthy of some study. Three are horizontal dials, one of English manufacture, and the fourth is a rare type of polar meantime dial.

Carrick Hill House

On arriving at this estate I had this extraordinary feeling of being back in England at a minor stately home, which, in a sense, it is. See Figs. 1 and 2.

The estate is located some 6 km south-east of Adelaide in the foothills of Mount Lofty Ranges. With an elevation of 150 m above sea level it is just a little cooler than the Adelaide plain. This beautiful estate was the result of the marriage, in 1935, of members of two of Adelaide's most prominent families. Edward (Bill) Hayward was a son of the wealthy merchant family that for more than 100 years owned John Martin's Ltd, once Adelaide's greatest department store. His bride, Ursula Barr Smith, was a daughter of an even wealthier family of pastoralists or farmers. The land was given as a wedding present and during their year-

long honeymoon they acquired much of the sixteenth, seventeenth and eighteenth-century panelling, doors, staircases and windows from the demolition sale of Beaudesert, a Tudor mansion in Staffordshire, England. A family friend, Adelaide architect James Irwin, designed the house around these fittings, and while the overall appearance is of a seventeenth-century English manor house, it incorporates all 'the latest' in 1930s technology. The house was under construction from 1937 to 1939, and at the same time, Ursula designed the garden. After distinguished service in the Second World War Edward Hayward and his wife continued filling the house with a wealth of paintings, sculpture, antiques and drawings spanning nearly 500 years of artistic achievement.²

The dial is a substantial octagonal casting, 275 mm across the octagonal flats, with time intervals every 10 minutes, a statement about correcting for the equation of time, an inner 'table' of the equation of time, and finally a compass rose,



Figs. 1 and 2. The Carrick Hill House and gardens. Although apparently an English garden, the trees in the middle distance in Fig. 1 are Sugar Gum (*Eucalyptus cladocalyx*) that are native to limited parts of Australia, and the bird on the lawn is an Australian magpie. Suburban Adelaide is in the distance.



Figs. 3 and 4. The sundial on a very well moulded pedestal. The small plaque says "Donated by The Friends of Carrick Hill"; details of the mottoes are given in the text.



John Ward



Fig. 5. Detail: Olde Adelaide Sundial, Latitude 34° 56' S Longitude 138° 35' E, Powell Bros Brassware Adelaide Est. 1914. Clock time is found by adding the minutes opposite today's date to the shadow reading of the sundial.

(Figs. 3 & 4). Other detail is given in the figure caption for Fig. 5. The gnomon is particularly elegant. When seeing the dial cast in relief I immediately thought of Sundials Australia who have specialised in making such dials, but this *appears* to be earlier. The brass founders, Powell Bros, (Fig. 5) are still in business in central Adelaide, and the dial is quite modern having been purchased from a distributor in March 2006. This may explain the more 'general' latitude angle of the gnomon of nearer 34° from a recent measurement.³ Similarly, Carrick Hill House coordinates are 34° 58' 44" S and 137° 37' 53" E, rather than those of central Adelaide as on the dial.

A striking feature of the dial to sundial enthusiasts is that the equation of time is markedly different from the usual sequence of numbers. This is due to the incorporation of the longitude correction compounded by South Australia's unusual time zone of half-an-hour difference from 'convention' and from its neighbouring states. It is 9½ hours ahead of GMT, only half-an-hour after the eastern states, but 1½ hours before its western neighbours. With this arrangement, the time zone is centred on 142.5° E, and Adelaide's longitude gives an addition of 15min 40sec to the equation of time. This results in the table of corrections against the relevant dates ranging from plus 30 minutes in mid-February to minus 1 at the beginning of November.

The pedestal is also very elegant and carries two inscriptions: on the base *We are travelling each towards his sunset* and on the capital there are three words *Time: Treath: Truthe*. Neither appear in the British Sundial Society's Register of Fixed Dials as mottoes. I have not been able to find a source for the former, but the latter, with very minor changes to *Time Tries Truth*, makes much more



A second dial, Fig. 8, is much more interesting. A plaque near to the dial repeats parts of the inscriptions on the dial and pedestal and states "The sundial was bequeathed to Seymour College in 1970 by



Figs. 6 & 7. The dial in Seymour College dedicated to the memory of Irene Duguid. At the upper part is a rather discreet inscription "Flowers bloom if love tends". In the lower centre there is the 'historical' date "1693" and "Each Houre is Reckoned". At each lower corner there is "Irene" and "Duguid".

sense. In fact in one book of proverbs,⁴ the origin is traced back to 1526, with variations as *Let time try!* and *Tyme Tryeth trowth in euey doubt*, and later (1580) *Time trieth the troth, in euerie thing*. Another⁵ gives *Time tries all things*, with variants including 'time trieth truth' and a similar phrase by Shakespeare in the Winters Tale 'Time, I, that please some, try all'. [See also Postscript p. 21.]

The pedestal itself has an interesting history. The current chief groundsman, Robert May, cast it in a fine concrete from a fibreglass pattern that he had made from a now-collapsed pedestal at his daughter's school, St Peter's Girls College, Adelaide. A visit by Margaret Folkard and John Ward was useful in explaining the details and setting the dial more accurately.

Seymour College

Founded in 1922, Seymour College (formerly Presbyterian Girls' College) is one of Australia's leading independent day and boarding schools for girls, from Pre-school to Year 12, and with some 850 students. The College is situated in extensive grounds, 5 km from the Adelaide Central Business District. The College has some fine heritage buildings set in 10 hectares of gardens, playing fields and courtyards.

The first dial, Figs. 6 and 7, came into the ownership of the College as a memorial gift from one of their first medical officers, Dr Charles Duguid, and was dedicated on 1 May 1929 to the memory of his first wife, Irene, who was a keen gardener.

The dial plate, 390 mm square, is mounted on a marble capital and elegant column, and the base of the column has two engraved labels. One carries the inscription that it is the gift of Dr Charles Duguid in memory of his wife, and the other states that "P.G.C./Seymour Old Collegians' Association restored the surrounds of this historic Sundial to mark their 80th Anniversary 2004".

Fig. 8 (right). The second dial in Seymour College with a combination of a carved corbel, a Kew Bridge pedestal and a granite base. The dial is almost certainly by Barkers of London. The gnomon went missing sometime in the 1980s, although a 1982 photograph has sufficient detail to enable it to be replaced.



Figs. 9 and 10 (far right). An inscription on the dial plate states "This head is a relic of old Christ's Hospital Blue-coat School founded 1553 by Edward VI demolished 1902-3 in the reign of Edward VII for the new and more commodious buildings at Horsham Sussex".



Miss Mary Anderson, a generous benefactor to the school. In March 1986, it was restored and transferred to its present position from the Junior School staff car park where it was in danger of decay." The plaque refers to the corbel as being in the shape of a leopard's head, almost certainly a misdescription.

Technical aspects of the dial are that it is engraved, of good quality, and from another photograph of the top, measurements of the hour angles show that it has been made for a latitude of about 34° S. Careful measurements of the dial itself may show that 35° S (the latitude of Adelaide) is the design latitude. This is supported by the discovery of the numbers 1 and 35 punched underneath where the gnomon would be fitted. Presumably the 35 is a reminder to the workshop for attaching the correct gnomon!

I sought advice about the dial plate from our Editor, John Davis, who has specialised in the engraving styles of many of our 17th to 19th century dial makers. He is also interested in the detailed numbers of the equation of time as it sometimes helps with the dating of a dial, which in this case is more conventional, that is, without the longitude correction as in the Carrick Hill sundial. I quote:⁶ "I think there is a strong possibility that the dial is by Barkers. Although the dial is in an earlier format, the style of the lettering (especially the capitals E and S etc.) is Art Nouveau or even Art Deco. The infill of the compass points is quite like some other Barker dials and more modern than the early C19 mathematical instrument makers. I suspect that the small numerals on the EoT scale were punched whereas the rest of it is hand engraved. The oakleaf border is quite well formed and so it seems the makers were still proud to be London Freemen. The data in the EoT seem to come from mid- to late-19C. It is definitely earlier than that in Gatty⁷ and also, possibly, by [clockmaker and sundial maker] Dent in 1875 though not by much."

The other feature of this sundial is the carved stone head, and in the opinion of David Brown,⁸ probably representing a satyr. [The Oxford English Dictionary defines a satyr as (in Greek mythology) a lustful, drunken woodland god, represented as a man with horse's ears and tail, or (in Roman myth) with a goat's ears, tail, legs, and horns.] In addition, David supplied a copy of an F Barker sales leaflet, dated after about 1903, which offers sundials and Kew Bridge balusters as pedestals. (Later brochures offered cheaper replica identical pedestals, so that demand may have exceeded the limited supply.) This particular leaflet has another page that mentions "Sun-dials formed from the Stonework of old Christ's Hospital (Bluecoat School)..." and lower down "We have a small quantity of this stone uncut



Fig. 11. An inscription on the pedestal states "This pedestal is a relic of old Kew bridge erected in 1782 in the reign of King George III and demolished in 1902 (coronation year of King Edward VII) for the present structure which was opened by His Majesty May 1903".

which can be converted into Base Stones for Sun-dial Pedestals, &c. We have also a few of the Sculptured Stone Caps, being models of those formerly worn by the boys, Carved Stone Pudding and Plate and Sculptured Heads, all of which formed part of the architecture of the old school. These can be converted into Sun-Dials to order.” (Christ’s Hospital was founded in 1552 by the young king Edward VI on land originally occupied by the monastery of Greyfriars, which suffered during the dissolution of the monasteries by Henry VIII.)

Given the potential early date of the corbel, I had hoped that it may even be of Roman origin (such a ‘pagan’ carving is hardly of monastic connections) and I enquired of the Museum of London, who in turn referred me to one of their architectural consultants, Dr Mark Samuel. His opinion is limited by not being able to examine the corbel directly, and stated ⁹ “It is not possible to say much from a 2-D image but it looks like the stone may be architectural in origin. It seems to be carved to fit between the springing of two arches. The white marble may be Italian (Carrara?) and the face seems to be that of a satyr. A Renaissance piece? Someone’s souvenir of a visit to Italy?”. In other words, the stone head could be of some antiquity beyond 450 years.

Taking the style of the sundial, the ex-bridge pedestal and the reference to a former Christ’s Hospital “Sculptured Head”, makes it almost certain that the Seymour College dial came from the workshop of F Barker & Son, Clerkenwell Road, London. The dial was given to the College by way of a bequest in 1970 from a Miss Mary Anderson who is recorded as a generous friend of the College, and in 1959 the library was named after her in recognition. In spite of enquiries,¹⁰ contact has been lost with the Anderson family, so that who commissioned the dial in the early 1900s and had it shipped to Adelaide, remains a mystery. My personal opinion is that the dial, carved head of a satyr and slim Portland stone pedestal, is a very odd combination, and examination of the Society’s Register of sundials in the United Kingdom has not revealed anything similar.

Pioneer Women’s Memorial Garden

Just north of the Governor’s Residence is a small garden dedicated to the pioneer women of South Australia. The garden was designed by landscape designer Elsie Cornish and the lovely languid statue was created by Ola Cohn and unveiled on the 19 April 1941. (Ola Cohn, 1892-1964, born Carola Cohn in Bendigo, was an Australian artist, author and philanthropist best known for her work in sculpture in a modernist style, posthumously awarded an MBE in 1965.) At the base is a very unusual polar sundial, and judging from the orientation of the base – almost exactly facing north, south, east and west – and the angle of the sloping surfaces at the angle of latitude strongly suggests that the dial was part of the design from the outset.

A starting point for the research about the astronomer, Charles Dodwell, was the Astronomical Society of South Australia, and their Honorary Secretary¹¹ supplied a wealth

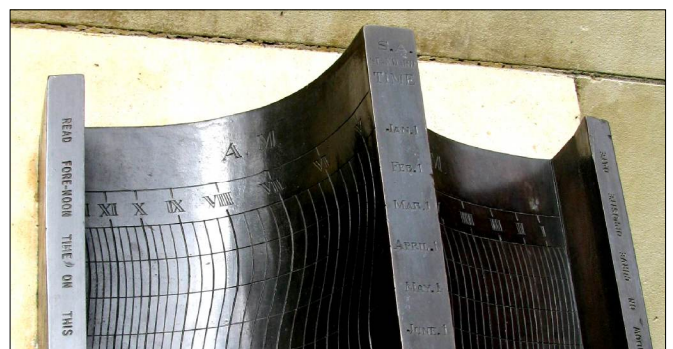

Fig. 12. The statue and bronze sundial at the base in the Pioneer Women’s Memorial Garden between the Governor’s Residence and the River Torrens.



Fig. 13 (above). The unusual polar meantime dial by a professional astronomer at the base of the statue. The inscription below the dial states “Sundial designed by Charles E Dodwell Esq. Government Astronomer 1941”. In this photograph the time is read from the edge of the shadow on the left hand (morning) side.

Fig. 14 (below). The polar dial gives meantime by ‘adjusting’ the normal altitude hour lines with the equation of time.



of material. Dodwell was born in Leighton Buzzard, Bedfordshire, on 13 February 1879 and died in Adelaide on 10 August 1963. At the age of 20 he became an assistant at Adelaide Observatory (1899-1909) and obtained a BA degree at the Education University of Adelaide in 1905. He was appointed Government Astronomer, South Australia, from 1909 until 1952, presumably on retirement. Official New South Wales government records give an outline of Dodwell's involvement with an eclipse of the sun in September 1922 at a desert location (camels were used to transport equipment) and that Dodwell travelled to the site after visiting the Astronomer Royal, in Greenwich.¹² The Adelaide astronomical observatory under Dodwell played a prominent part in fixing the meridian boundary between two states in 1921 by the then unique method of using radio time signals from Radio Bordeaux and Radio Lyons, France. Other valuable work which brought the Adelaide observatory into world recognition included a magnetic survey of South Australia and latitude variations worked in conjunction with the La Plata, Argentina, Observatory and the International Latitude Congress and the International Astronomical Association.

The dial is a substantial bronze casting, some 40 cm wide, 42.5 cm long and about 16 cm from the base to the central ridge. It is in the form of polar dial, about 40 cm (15.5in) wide and 42.5 cm (16.75 in) long and about 16 cm (6.25in) from base to central ridge. On the left hand edge the instructions are "Read fore-noon time on this side by shadow on curve opposite date". The central spine is marked S.A. Standard Time with the months starting with Jan 1 at the top, and the right hand edge is engraved "Read after-noon time on this side by shadow on curve opposite date".

The form of dial may be traced back to the half cylinder with a central long rod gnomon, for example Ferguson's Solar Chronometer, which is pictured on p.192 of Cousins.¹³ Dodwell has split the cylinder in two and applied vertical 'edge' gnomons, and also 'straightened' the curved surface which makes the dial easier to read. Furthermore, the whole year is catered for whereas the Ferguson dial, and others like it, cover six months at a time, and need a time card for each half of the year. Another feature of the Dodwell dial is that the hour lines are displaced to accommodate the 4° that Adelaide is to the west of its non-standard half hour time zone longitude of 142.5° E.

To take the extra step and make it a mean-time dial is to incorporate the equation of time, as shown in the wavy lines in Fig. 14. This method has been used in Ferguson's dial, but does contain the hidden paradox that hour lines would normally be straight as in a conventional polar dial, whose positions are dictated by the declination of the sun. In other words such dials are also *altitude* dials, and because solar declination only varies with the seasons, they do not contain the Earth's orbital/rotational 'solar position component' that gives the equation of time. It follows that the normally straight hour lines are 'bent' for the *convenience* of showing mean time. This form of correction can also be

expressed as an 'unfolded analemma' where the time corrections are drawn to scale on the hour lines, which gives a much shallower curve than is usually shown in books or other graphical displays.

An interesting challenge is to speculate how Dodwell made the dial. Several years ago there was some correspondence on the international Sundial Mailing Group (sundial@uni-koeln.de) and both Peter Mayer¹⁴ and Edley McKnight¹⁵ supplied me with more details. They speculated on the form of the curved surface and a super-ellipse gives a close fit to the shape. (A super-ellipse is an ellipse with the exponent in the equation greater than 2 which gives a 'squaring' effect such as a shape like a rectangle with rounded corners. Mayer estimated that the exponent for the Dodwell dial is 2.5. See also the recent article by Mills¹⁶ which contains the mathematics of the super-ellipse.) On the other hand, the shape could have derived from a template that simply 'looked right' and it is highly likely that the modified hour lines were painstakingly calculated by projection. The curves were almost certainly skillfully engraved in the bronze by hand.

Despite having an equation of time correction, care is needed to obtain time to better than a couple of minutes. It does, though, fit many of the criteria for a good sundial - it is very robust, easy to read, is a meantime dial, and makes a handsome contrast to the delicacy of the statue.

ACKNOWLEDGEMENTS

To Margaret Folkard for giving me the locations of the dials during my visit to Adelaide, and to other contributors mentioned below. I should add that all went out of their way to provide additional information.

REFERENCES

1. Douglas Bateman: 'Folkard and Ward, Sundials Australia - a visit report', *Bull BSS* 21(ii), 5-8 (Jun 2009).
2. The notes are from the Carrick Hill House website, www.carrickhill.sa.gov.au, with additional material from the House Director, Richard Heathcote.
3. Margaret Folkard and John Ward, Sundials Australia, private communication, (Mar 2010).
4. G.L. Apperson: *English Proverbs and Proverbial Phrases, a historical dictionary*, Dent, London, (1929).
5. David Pickering: *Cassell's Dictionary of Proverbs*, Cassell, London (1997).
6. John Davis, private communication, (Feb 2010).
7. A. Gatty (Ed H.K.F. Eden and E. Lloyd): *The Book of Sundials*, George Bell and Sons, London, (1900).
8. David Brown, private communication, (Jan 2010).
9. Mark Samuel, private communication, (Feb 2010).
10. Margaret Macdonald, Seymour College historian/archivist, private communication, (Mar 2010).
11. Ian Anderson, Astronomical Society of South Australia, private communication, (Feb 2010).
12. <http://about.nsw.gov.au/collections/tag/george-dodwell/28516>
13. Frank W. Cousins: *Sundials A simplified Approach By Means of the Equatorial Dial*, John Baker, London (1969).
14. Peter Mayer, University of Adelaide, private communication, (Mar 2010).
15. Edley McKnight, private communication, (Mar 2010).
16. Allan Mills: 'The Sundial as an Aeolian Harp', *Bull BSS* 22(ii) 2-6 (Jun 2010).

douglas.bateman@btinternet.com

THE BENARES (INDIA) SUNDIAL IN THREE DIMENSIONS

JOHN WARD, MARGARET FOLKARD and RON BLUM

One of us (RB) has been deeply involved in every aspect of stereography during the past 42 years and has the largest collection of stereo views in Australia. These are stereoscopic images mounted on cards that were used for home entertainment over 100 years ago. RB has amassed a huge collection of stereographs by the noted Australian photographer George Rose who produced stereo views from the 1880s to the 1910s before switching to postcard production.

Many years ago, MF and JW of Sundials Australia (both retired physicists), created two optical, stereographic, polarisation type projectors, one for RB and one for Sundials Australia. In addition, we designed and made a most unusual device called an autocyclostereoscope.¹⁻³ This device enabled the projection and viewing of images in full 3-dimensions without the use of special spectacles such as the anaglyph (red and blue) or polarisation type commonly used in modern times. A brief description of the device is given below.

The Autocyclostereoscope

A cyclostereoscope is a concept for the autoscopic viewing of projected 3-dimensional images. The two words are usually combined and result in 'autocyclostereoscope'. It was perfected in the 1940s by Françoise Savoye of France.¹ After the war, it was shown to theatre audiences at Luna Park in Paris. For many years smaller systems were sold for home use by Etablissements A. Matthey of Paris.

The concept consists of a grid of venetian blind type material mounted on an inverted cone which rotates fairly quickly around a stationary screen, as shown in Fig. 1.

Fig. 1. The Autocyclostereoscope.



The left and right images are projected through the grid onto the screen. A beautiful, 3-dimensional image is seen without the aid of glasses. Simultaneously, a large angular field of view is obtained.

The Benares Sundial

You might well ask, how is this preamble related to sundials?

In 1902 George Rose went to India to photograph the Delhi Durbar in 3-D and produce stereographs for the home market in Australia. The Durbar was a great celebration in which King Edward VII was proclaimed King and Emperor of India on the 1st of January 1903. In India, a 'Durbar' (the Persian word for 'Court') is a court or audience chamber or any formal assembly of notables called together by a governmental authority. In British India, the name was specially attached to formal, imperial assemblies called together to mark great state occasions. The three most well known durbars were held in Delhi in 1877, 1903 and 1911. They celebrated in turn Queen Victoria's title as the Empress of India, King Edward VII's title as Emperor of India and the coronation of King George V and Queen Mary as the Emperor and Empress of the British Empire.

While George Rose was in India for the 1903 Durbar, he took a large series of stereoscopic photographs and included in this series was one of the virtually unknown Benares sundial. Figure 2 shows George's thirteen year old son Walter standing on the gnomon steps.

To help you view this 107-year-old stereograph of the Benares Sundial in full 3 dimensions, use the following method. Hold the image close to your nose, slowly move it away and suddenly the 3D image will appear. It sometimes helps to blink or squint rapidly several times. It is worth a little struggling with your eyes until the 3D image suddenly jumps out at you.

This large masonry sundial at Benares was built in 1737 on top of the Manmandir palace on the banks of the River Ganges in India. It was one of the five sundial observatories built by the astronomer prince, Sawai Jai Singh II.^{4,5} Maharaja Jai Singh was born in 1686 and at the age of thirteen ascended the throne of Amber, a small kingdom south-west of Delhi in present day Rajasthan. He was devoted to the study of mathematics and contemporary science. His study of ancient, astronomical texts led to the realisation that the astrological tables and charts available at the time did not tally with his own observations. The data obtained from these tables had a direct bearing on the scheduling of Hindu and Muslim religious rituals and festivals, so Jai Singh

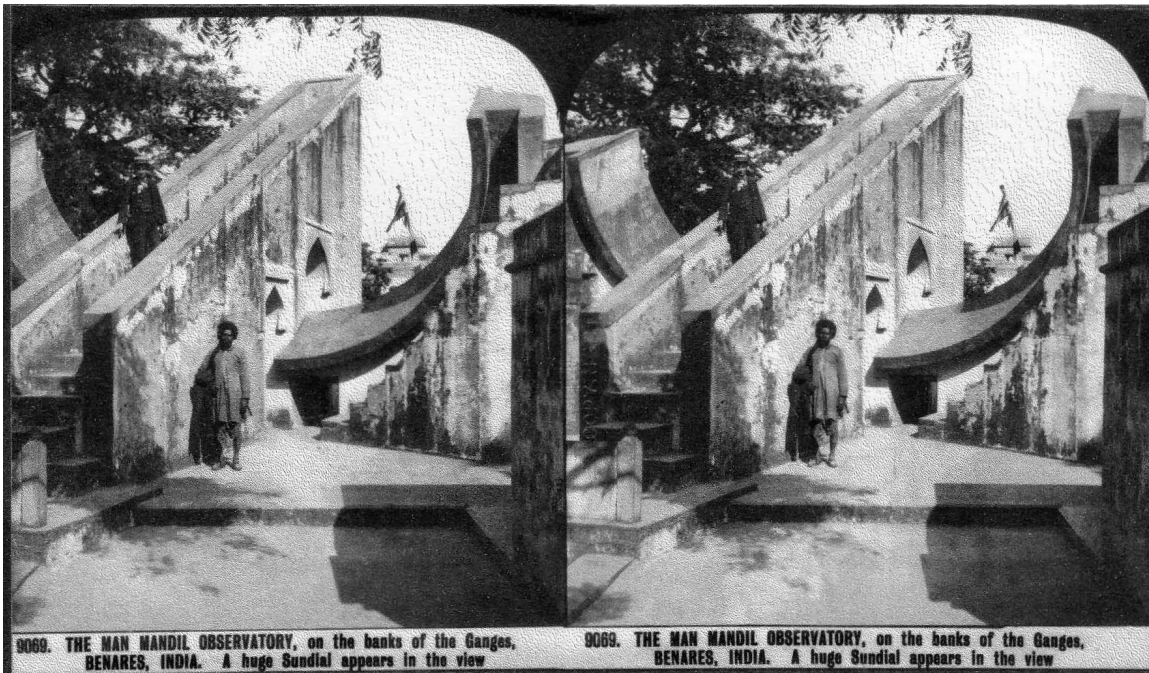

Fig. 2. The Benares Sundial.

decided to rectify these errors by building a series of accurate, time telling sundial observatories, in different locations in India.

The first sundial was built near Delhi in 1724 and the second (the biggest) at Jaipur⁶ was completed in 1734 (both visited by MF and JW on several occasions). The others were constructed at Mathura, Ijjain and Benares and were much smaller. The Benares sundial (in present day Varanasi) stands at only 22 feet or about 6.7m high, quite small in comparison to the 90 feet high, or 27 metres, sundial at Jaipur. Each of these equatorial type sundials had its gnomon correctly inclined at the latitude angle of its respective location and was aligned in a true north-south direction so that the tip of its highest point quite accurately indicated the North Celestial Pole. The shadow of each stone gnomon falls on to two large, stone quarter circle scales graduated in hours, minutes and most optimistically,⁷ in seconds of time.

Each of the five equatorial sundials was part of an observatory complex known as a Jantar Mantar which included non-optical instruments relying on naked eye observations. These other devices measured latitude, positions and movements of the sun, moon and planets and some were used specifically for astrological rather than

astronomical measurements. The instruments were mainly made of stone, but some, like the 2 metre diameter astrolabe at Jaipur, were made of bronze.

The smaller sundials like the one at Benares (Fig. 3) were used to check the accuracy of the bigger versions such as the very large sundial at Jaipur.

The Benares observatory was restored in 1912 by the Maharaja of Jaipur at that time. Since then, it has unfortunately lapsed into a state of disrepair. The finding of this stereograph, Fig. 2, has effectively been a trip down memory lane. Perhaps a reader of this article can update our knowledge about the present state of the Varanasi sundial?

Other Stereoscopic Pictures

To conclude this stereographic sundial story, it is appropriate to present a more recent stereographic print of an armillary sphere sundial made by Sundials Australia in Adelaide, South Australia. Figure 4 shows the wooden pattern for the armillary sphere sundial in the Royal Botanic Gardens Sydney (which featured on the front cover of the June 2009 *BSS Bulletin*) outside our workshop while Figure 5 shows it about to be delivered to the foundry for bronze casting. To view these figures in full 3D, use the viewing method described earlier in this article.

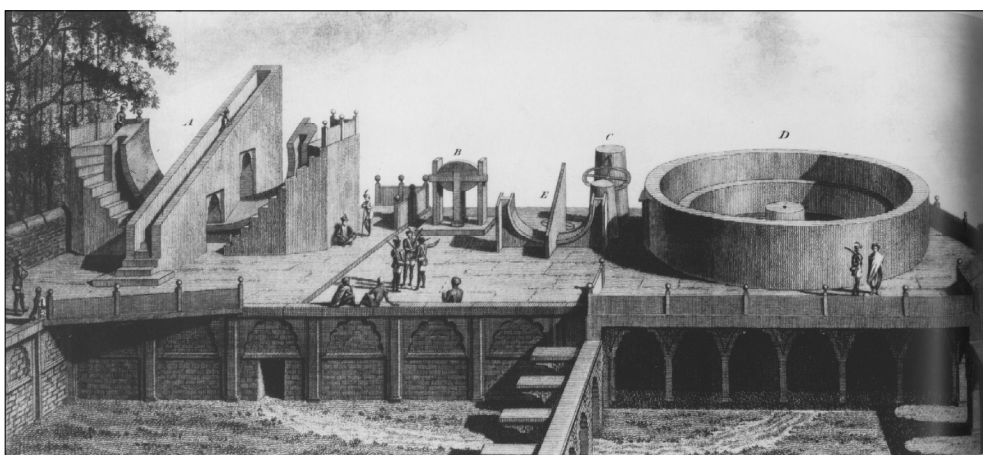

Fig. 3. 18th century engraving of the Benares observatory (after Ref 4).



Fig. 4. Wooden sundial pattern.



Fig. 5. Wooden sundial pattern about to depart for casting.

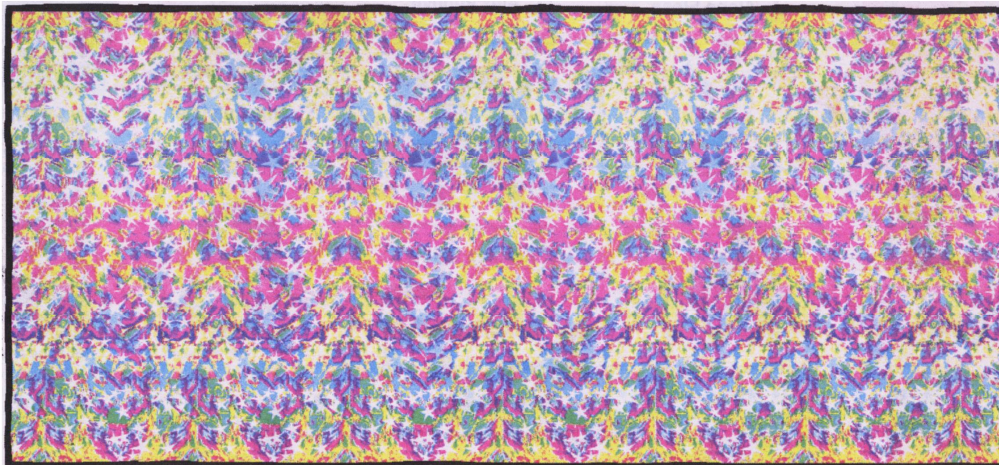

Fig. 6. A 3D surprise. See p. 8 for what you should see.

In passing, the Random Dot stereogram in Fig. 6 uses a quite different technique to produce a 3D effect. This should also be viewed using the method described above. To reassure those who have problems obtaining the 3D effect, MF often has difficulty but after sustained rapid, unfocussed blinking and squinting the 3D effect suddenly pops up and it seems extra dramatic after her unsuccessful efforts – so keep trying!

REFERENCES

1. F. Savoye: 'Les Systems de Cinema en Relief a grille mobile', *Bulletin of Association Francais des Ingenieurs Techniciens du Cinema*, 37-47 (1949).

2. Ron J. Blum: *Journal of National Stereoscopic Association (USA)*, 29-31 (May-June 1983).
3. The British Journal Photographic Almanac, 139-140 (1953)
4. Andreas Volwahn: *Cosmic Architecture in India*, Prestel-Verlag (Munich) (2001).
5. Dilip Salwi: 'The Wondrous Observatories of Jai Singh', *New Scientist*, 726-730, 92, No. 1283 (10 Dec 1981).
6. Daulat Singh Rajawat: *Astronomical Observatory of Jaipur*, Delta Publications, Jaipur (date not given but purchased in 2007).
7. Margaret Folkard & John Ward: *Sundials Australia*, Sundials Australia, Adelaide, (available from BSS) 86-87 (1996).

Authors' address:
sundialmarg@kern.com.au

A VERY LARGE POLAR DIAL IN LALÍN, GALICIA, N.W. SPAIN, DESIGNED BY JOSÉ LUIS BASANTA CAMPOS OF PONTEVEDRA

ALAN SMITH

This article has been compiled from notes and other material provided by the designer of the dial, translated from the original Spanish by Julia Patterson.

In December 2008 the Town Council of Lalín commissioned the architect J. Enrique Pérez-Ardá to design a multi-purpose building close to the local football pitch, which had to comply with the following conditions:

- single storey
- uninterrupted façade S-facing on to the football pitch
- approximate size 30m × 20m
- designed for a variety of uses.

The architect thought that in order to make this a noteworthy building a sundial might be included. Having seen José Luis Basanta Campos's book *Relojes de Piedra en Galicia* (the second and latest edition) he decided to consult with its author with a view to making this a joint sundial/building project.



Fig. 1. Aerial view of the site of the sundial building at Lalín.

Lalín is an agricultural and industrial town with a population of about 10,000, situated in the NE of the province of Pontevedra. It is well known for some distinguished past inhabitants, amongst them the artist Laxeiro, the presbyter Don Ramón María Aller (a mathematician and astronomer with an observatory) and the aviator Joaquín Loriga who became famous in 1926. The proposed building was to be constructed on the outskirts of the town, shown in the aerial view of Fig. 1, the selected site being a triangle bordered by two roads and one end of the football pitch. Having abandoned an earlier plan in which the long axis of the building declined some 4° from the true EW line Sr. Pérez-Ardá

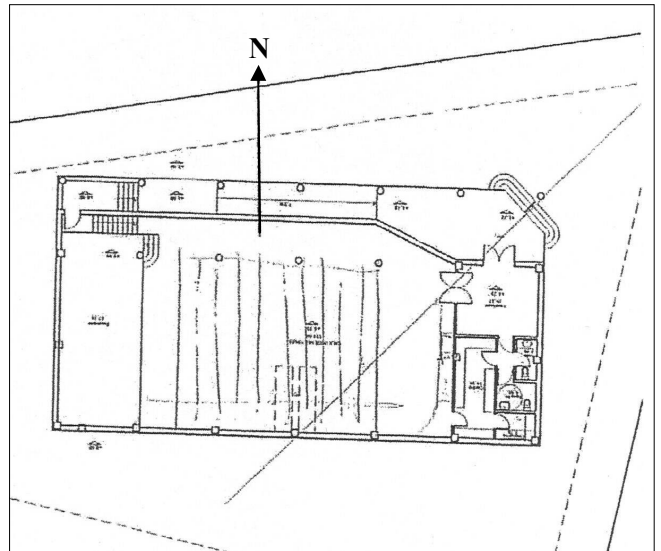

Fig. 2. Plan of the building showing its orientation.

produced a new plan following a series of meetings with Sr. Basanta Campos in which the idea of incorporating a sundial was a basic factor. This new rectangular design was arranged so that the central axis was placed true N-S and the south-facing roof was set at an inclination of 42° 39', being the latitude of the site and an ideal surface for a polar dial. There were to be no doors or windows on the south side and the entrance to the building was placed in the NE corner, seen on the plan of Fig. 2. Both the architect and the sundial designer felt that the new project produced a more aesthetically pleasing overall appearance and was the ideal solution for a polar sundial of unusually large size. The claim has, in fact, been made that it is one of the largest, if not *the* largest sundial in Europe (see Figs. 3 & 4).



Fig. 3. View of the building from the SW.



Fig. 4. View of the dial with its designer José Luis Basanta Campos.

The dial itself is 20 m × 10 m in size, on the 30 m × 10 m roof and the length of the gnomon is 3 m, which fitted well with the overall dimensions. The hour lines are graduated from 7:00am to 5:00pm and the first and last hours are divided by small numerals into ten minute intervals as can be seen in Fig. 5. Lines of declination, calculated for the 20th of each month, are provided as follows, with initial letters at each end of the lines:

D (diciembre)	D (diciembre)	(black)	Winter solstice
December	December		
E (enero)	N (noviembre)	(red)	
January	November		
F (febrero)	O (octubre)	(green) *	
February	October		
M (marzo)	S (setiembre)	(black)	Equinox
March	September		
A (abril)	A (agosto)	(green) *	
April	August		
M (mayo)	J (julio)	(red)	
May	July		
J (junio)	J (junio)	(black)	Summer solstice
June	June		

* (These appear green in the photographs but Sr Basanta Campos describes them as blue.)

The angles of declination were obtained from tables published by the BSS in 2009. The overall size of the dial can be appreciated from the photograph (Fig. 4) of Sr Basanta Campos standing in front of it. As the sun's declination throughout the year is shown it would, perhaps, have been useful to have used the spare spaces on each side of the dial

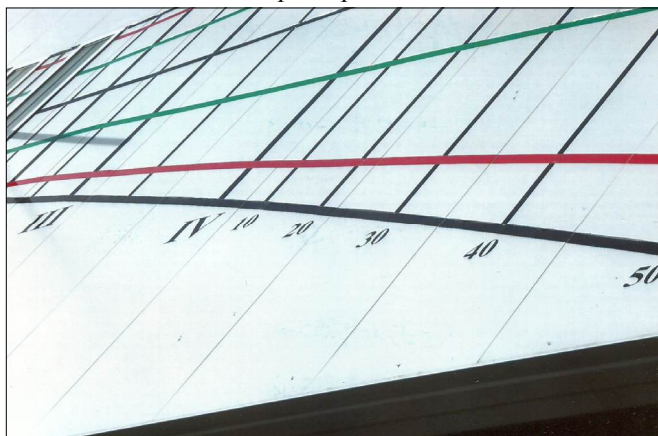

Fig. 5. Detail showing 10 minute intervals on the last hour.



Fig. 6. José Luis Basanta Campos testing his small scale model.

for signs of the Zodiac. These would also have added a decorative touch to the design. The roof is covered with a 'sandwich' of aluminium plates and fibreglass and the lines and numerals are applied using adhesive plastic such as is used for aircraft fuselages. These materials offer maximum weather resistance and durability.

In view of the fact that the longitude of Lalín is 8° 06' 53" W and the dial is calculated to show local time, (therefore about 32.5 minutes slow of GMT), and as Spain follows DST plus one hour in summer, it is not clear how spectators at football matches would be able to assess the time of day, to say nothing of the vagaries of the equation of time! However, with a little careful thought those watching football and noting the position of the shadow at the start of the game should be able to calculate half-time and the time of its conclusion.

A photograph of the designer, José Luis Basanta Campos is shown in Fig. 6 testing his small scale model of the dial, and he has dedicated this project to the memory of the late presbyter Don Ramón María Aller, a great astronomer and mathematician of Lalín.

Author's address:
a.smith13@homecall.co.uk

POSTSCRIPT from p. 13

In the September issue of the NASS *Compendium* (Vol 17, p.11, Sept 2010) there is a reference to the unusual motto Time Tries Truth. The report concerns the return of a sundial that was originally installed in about 1920, and more recently in store. It is being restored to its former location at a campus in Athens, Georgia, and quoting the UGA (University of Georgia) News Service reporter "The brass sundial, which is placed atop a three-foot high marble urn, features delicately hand-tooled Roman numerals and the inscription 'Time Tryeth Trothe – 1673'. Loosely translated from Old English, it means 'Time test faith' or 'Time tests truth'." Correspondence with Christie's, London, estimates the dial as late Victorian, probably 1870s to 1880s.

Douglas Bateman

THE CONSTRUCTION OF AN EQUATORIAL SUNDIAL WITH A REFERENCE TO ANAXIMANDER'S SKIATHERON

A. GALANAKIS, E. THEODOSSIOU & V.N. MANIMANIS

Sculpture is interplay of light with shadow. For our perception to 'read' a certain work it needs not only light to see it but also shadow marking parts of it in order to 'describe' it. In the special case of an artistic sundial, the shadow, besides being an element of description of the work itself, yields specific information.

The fascinating '*Anaximander's skiatheron*' served as inspiration for one of the authors, sculptor Andreas Galanakis, to approach the creation of the sundial described here. This *skiatheron* is depicted in a Roman mosaic, now in the Rhineland Museum (Trier, Germany), which shows the philosopher Anaximander holding it, resembles more a butterfly than an instrument.

Diogenes Laertius (B, 1) reports that Anaximander (Fig. 1) was the first to construct a 'gnomon' showing the solstices and the equinoxes and set it in Greece. This happened in Sparta, circa 545 BC, i.e. near the date of his death.¹

"He also was the first discoverer of the gnomon, and he placed some in Lacedaemon on the sun-dials there, as Phavorinos (FHG iii 581) says in his *Universal History*, and they also showed the solstices and the equinoxes; he also made clocks..."

(*The Lives and Opinions of Eminent philosophers*, literal transl. by Charles Duke Yonge, 1853.¹)

The Concept

The shape of the sundial as it is depicted in the Roman mosaic is at the same time graceful and unusual. The passage of the shadow from its plate seems to introduce the viewer into another 'dimension', most unlike the reading of the

hands of a simple mechanical clock. It is almost as though it shows another kind of time. A sundial is a point of reference and orientation for a given place, while to some people could even give some motivation for philosophical thinking: metaphorically speaking, the viewer of a sundial is led to the sense that the silently sliding shadow of the gnomon, which every moment separates the surface of the plate into past, present and future, represents the incessant motion of the Universe. The shadow of the light coming directly from a star, our Sun, prompts for a meaning beyond the reading of the hour numbers. Any sundial is a valuable counsellor and also a piece of art that assigns a deeper meaning to our measurable time. Moreover, it requires the place of a work of art, wherever it is set.

The challenge, therefore, for the sculptor/constructor of the sundial was to devise an instrument as an operational work of art. He decided that the sundial should be equatorial; first of all because this form gives more opportunities for development in the surrounding space than horizontal, vertical or polar sundials; in addition, the sculptor wanted this work to connect an obvious reference to the past (Anaximander's *skiatheron*) with a futuristic facet, a reference to the future.

His sundial should resemble more a design or drawing in the three dimensions than a robust monumental sculpture. So the proper selection of its material would be very important to obtain this result. 'Heavy' materials such as marble, cement etc. were excluded under these initial terms. In order to assign this character to the piece of art, the medium



Fig. 1. Anaximander represented with a sundial. Mosaic (3rd century AD) in the Rhineland Museum (Trier, Germany).



Fig. 2. The illuminated hour plate creates a contrast with the un-illuminated body of the sundial.

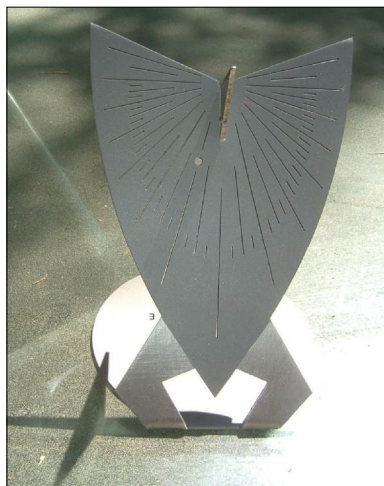

Fig. 3. The first version of the hour plate.

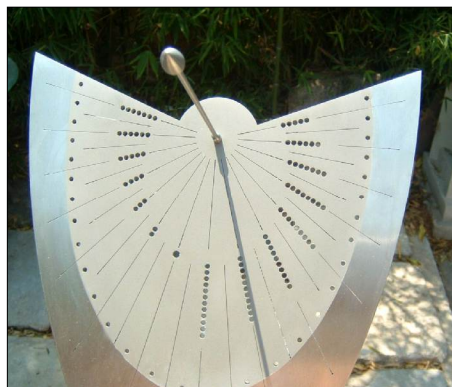

Fig. 4. The second version of the hour plate.



Fig. 5. The final form of the hour plate.

should be of small thicknesses and consequently a strong metal. The next thought was to make the plate of bronze; however, this would ‘send’ the work back into the ‘motionlessness’ of the past. Bronze resembles gold in colour and metaphorically points to something pompous and heavy.

The selection of stainless steel (inox) gave the flexibility the sculptor was searching for. This metal seems to lose its material essence as light reflects on it. It was not polished, in order to avoid an extraterrestrial appearance and a vivid reflection of the sunlight that would cause problems in the reading of the time. On the contrary, the stainless metal plate was slightly matted; it was subjected to a light sand-blasting to make the gnomon shadow more visible and free of blinding reflections of the rest of the surface.

The Hour Lines and Numerals

The geographical latitude and longitude were first determined by GPS at the site of the original presentation and exposition of the sundial; its readings were subsequently checked versus *Google Earth*[®] software indications, which verified the GPS readings, i.e. latitude 37° 56' 24.7" N and longitude 23° 41' 46.2" E.

It should be noted here that the site where the sundial is now differs from that initial site by approximately 1 km to the northwest; this difference is negligible for the proper operation of the sundial, although the arc second parts of the above numbers will have changed.

The hour plate was divided into hours with lines every 15 degrees, as any sundial requires. There are also lines for the half-hours, with additional lines carved every 7.5°. Dots (corresponding to small depressions) were used to denote the hours for aesthetic reasons, so that the plate would not have just linear carvings. Small holes were also carved for the quarter-hours around the circumference, so that they form a nice ‘necklace’ on the sundial’s hour plate. Another point to decide was the type of indications of the hour numbers. The sculptor did not want to use the Arabic numerals because they would appear too ordinary, but Roman numerals, would metaphorically point to a ‘heavy’ and slow pace.

On the other hand, the ancient Greek numerals, which are the letters of the Greek alphabet, would restrict our reference only to the ancient Greek past, after the main *skia-theron* concept, thus losing in ‘timelessness’. The final idea was for each hour to be identified by just the number of the dots used in the place of hour lines, hinting to the diachronic character and grace of a primal numbering. To this decision contributed another reason: the aesthetic appearance of the work illuminated at night.

The Appearance at Night

Instead of a simple ‘blind’ carving of the hour plate, the sculptor created, by illuminating it at an oblique angle from below, a contrast between the linear carvings and the holes-dots. Essentially, the illumination is centred on the hour plate, which thus appears as floating in the air, because the supporting structure is un-illuminated.



Fig. 6. The first wooden model.

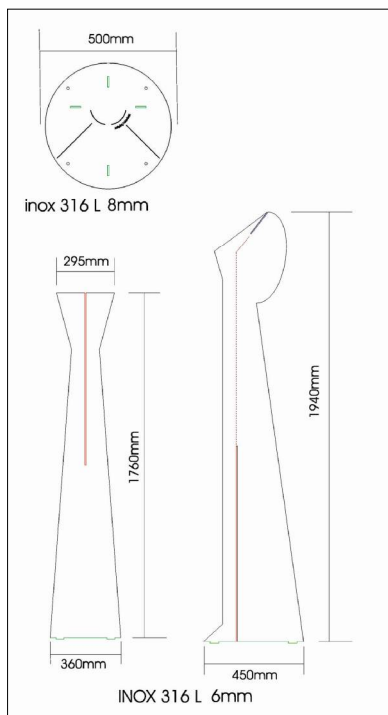
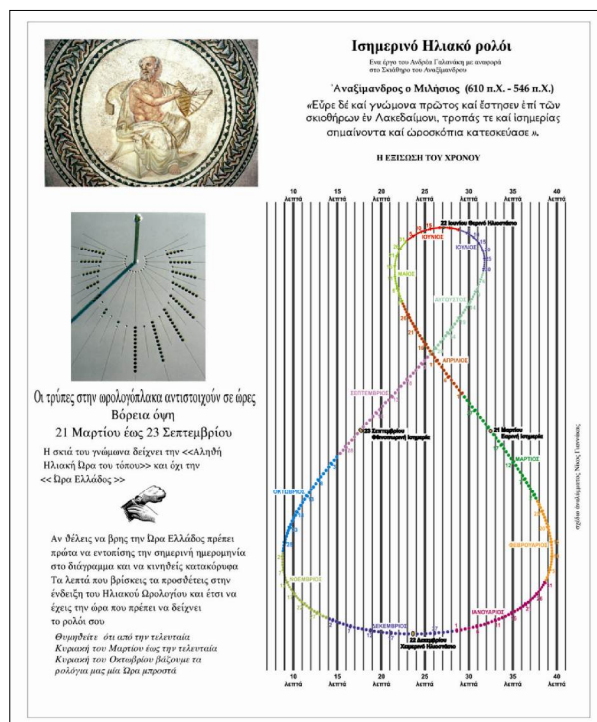

Fig. 7. The construction process.

Fig. 8. The 'explanatory' plaque showing Anaximander as depicted in the Roman mosaic, the equation of time with the appropriate explanations, and directions of how to use the sundial, and the reference of Diogenes Laertius to Anaximander (upper right).



The Construction of the Sundial

For the construction of the whole work, the first step was to make some drawings similar to the *skiatheron* held by Anaximander in the Roman mosaic. Next, a small model prototype of the plate in MDF was constructed in order to see the work materialized in space.

The following step was to design the plate in the computer and then 'cut' it in metal to test the material used. After sand-blasting, the first draft was ready. It was also attractive enough for some copies to be given as gifts to friends living around Athens (with a similar latitude, 38° N).

A second version followed. This version was better; however it seemed too 'modern', losing somewhat in diachronic character by taking a rather abrupt and self-conceited jump to the future. Nevertheless, its constructor liked it thus he completed it. This model was on a scale 1:2 with respect to the final size and helped the artist to a better understanding of various details of the construction.

Another hour plate followed, this time a full-scale version. Its thickness was 6 mm. The engravings were seen to be too narrow to show well, having a width of just 0.7 mm, so they were widened to 1.2 mm, which finally proved to be a satisfactory value.

Gradually, the work started to mature as a construction after these tests and the hour plate took its final form, which appears in Figure 5. This had the proper width and length of hour lines, as well as the optimal diameter for the dots-holes.

The corresponding drawings were made with a computer, using the *CorelDRAW 13* software. The guides were glued to wood/MDF and then cut. The wooden model was in full size and was placed in the backyard of the artist's studio. Additional corrections were made upon the final model and then the last drawing took place.

Then the pieces were laser-cut from 6 mm inox, with the relative difficulties imposed by the accuracy of such a construction. The whole work consists of four pieces plus the gnomon. The sculptor thought a lot on the issue of indicating the solstices on the hour plate; he finally decided not to carve them, as they would render the whole plate more complex to read. The gnomon was made relatively large, 23 cm long, for both aesthetic and practical reasons, so that on the occasions when the shadow length is minimum, the shadow would still cover the whole hour plate.

In Fig. 7 the parts indicated in green were attached by TIG welding very carefully, so that the metal would not 'tear'. The red parts were glued with a two-part epoxy. A problem that emerged was the slight bending of the plate under its own weight: it was deflecting downwards by about 1 mm at its highest point. For this reason, a lot of effort was made to pre-tension the plate, so that it would counteract the bending, avoiding inaccuracies at the equinoxes.

The EoT Plaque

The equation of time along with other descriptions – guidelines to the use of the equatorial sundial – were printed and placed under a thick (8 mm) glass glued upon their stainless plaque. This plaque was mounted on a separate base next to the sundial.

The sundial was a donation of the Eugenides Foundation on the occasion of the International Year of Astronomy 2009, while the Borough of Palaio Faliro, south of Athens, hosted it for six months in its seashore park.

Afterwards, at the end of the year, the sculpture-sundial was transported, in early March 2010, to the entrance of the Eugenides Foundation (387 Syngrou Avenue), 1 km from Athens, where there is the modern planetarium with the second largest dome in the world.



Fig. 9. The equatorial sundial in the seashore park of the Palaio Faliro Borough.

Some Technical Comments

Just three months after its placement in the Palaio Faliro seashore park, in December 2009, the side that faced the sea (south-southwest) had already signs of rust. The southwestern wind blowing in Faliro since the time of Anaximander comes from Libya (it retains the same name: *livas*) is humid and moreover it carries with it droplets of sea water, the salt of which can deteriorate almost everything. The other (northern) side of the sundial plate was almost intact.

Of course, this was a surface rust, which went away rather easily with a cleaner for stainless materials; however, this incident was a reason for another sand-blasting followed by a conservation spray varnishing with matt varnish for the hour plate only (not the mounting). The gnomon was polished. The final result was very good.

The sundial-sculpture was installed next to the main entrance of the Eugenides Foundation (Syngrou entrance) before March 8, 2010, the date of the inauguration of a new exhibition in the Foundation. Here, at its new site, the sea wind and salt would have a very limited influence.

The technicians of the Eugenides Foundation had already prepared a cement base-pedestal for the sundial. A stainless steel cylinder, 70 cm in both diameter and height, was prepared; a pit 50 cm deep was dug, filled with 10 cm of ce-

ment, levelled and on top of this cement base the cylinder was placed. Then the rest of the pit and the interior of the cylinder were filled with cement. On top of the cylinder a horizontal white marble slab was placed and upon this marble the mounting ('trunk') of the sundial was placed and screwed. On March 8, 2010, the evening of the inauguration of the Melina Mercouri Exhibition, the sculpture-equatorial sundial was ready and illuminated.

REFERENCE

1. Diogenes Laertius: *The Lives and Opinions of Eminent Philosophers*, transl. by Charles Duke Yong. Ed. H. G. Bohn, London, 1853.

Authors' address:

*Department of Astrophysics-Astronomy and Mechanics,
Faculty of Physics, National and Kapodistrian
University of Athens, Panepistimiopolis, Zographos
157 84, GREECE.*

andreas14@otenet.gr and etheodos@phys.uoa.gr

Postcard Potpourri 18 Lochgoilhead, Argyll

Peter Ransom

This is an early colour postcard of the multi-faceted obelisk dial at Lochgoilhead in Argyll. According to the *BSS Register 2005*, (SN 1190) it was made of sandstone in 1696(?)

and is mentioned in Andrew Somerville's book *The Ancient Sundials of Scotland*. The initials DHM for Dame Helen Maxwell and SCC for Sir Colin Campbell can be found on the structure. The postcard shows the five square panels below the central polyhedron and the six panels on the tapering finial. It stands on the lawn in front of 'The Cottage'.

The postcard is postmarked Lochgoilhead Ju 14 1909 and the message informs us that Liz thinks 'This is best place we have been to yet.' Must have been the dial that made it for her!



pransom@btinternet.com

Yiannis Papamatheou

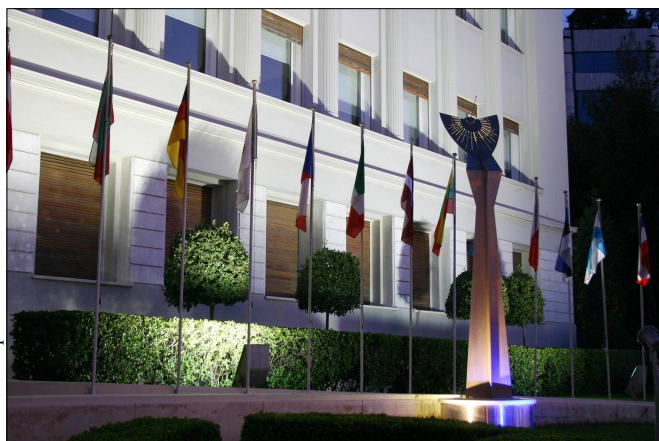

Fig. 10: The entrance of the Eugenides Foundation with the illuminated equatorial sundial.

MERIDIES MEDIA – AN HISTORICAL ESSAY

The Direct Vertical Noon Mark Mean Time Sundial at Greenwich

CHRISTOPHER DANIEL

On the 15th November 1967, Dr Tadeusz Przykowski (1905-77), Director of the Museum Przykowski in Jędrzejów, Poland, signed and dated the drawing that he had just completed of his design and delineation of the *Meridies Media* or Noon Meantime sundial, proposed for the old Royal Observatory at Greenwich.¹ Dr Przykowski had recently received a commission from the National Maritime Museum at Greenwich to produce designs for a number of sundials that were intended to adorn the walls of the Old Royal Observatory (ORO). This had become an integral part of the Museum when the Royal Greenwich Observatory had moved down to Herstmonceux Castle in Sussex.



Fig. 1. D.W. Waters (left) showing A.P. Herbert and his secretary around the new ORO galleries.

Fig. 2. The original sundial as designed and delineated by Dr Przykowski.

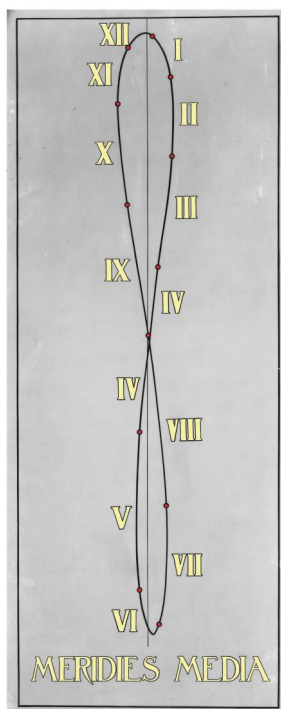

The idea of enhancing the walls of the ORO with sundials must certainly be attributed to Lieutenant-Commander David W. Waters, R.N., formerly Historian to the Admiralty and the distinguished author of a scholarly masterpiece on Tudor navigation, published in London in 1958.² When I joined the staff of the National Maritime Museum (NMM) in 1964, Waters was Head of the Department of Navigation & Astronomy, to which department I was appointed as a Research Assistant (I), in the Astronomy division. In 1967 he gave me curatorial responsibility for the sundial collection, on display in Flamsteed House, in the ORO. It was early in this same year that A.P. Herbert's light-hearted book on sundials was published, for which

Waters had written an enthusiastic foreword in March 1965.³ On the 14th July 1967, A.P. Herbert visited the museum and was given a guided tour of the newly refurbished Meridian Buildings of the ORO, with their new galleries, relating the history of the observatory (Fig. 1).⁴

However, the seeds of this idea had evidently been sown a number of years earlier, since, in the summer of 1960, following what was probably the opening of the sundial display in Flamsteed House, Francis Maddison, then Assistant Curator at the Museum of the History of Science at Oxford, wrote to David Waters concerning Dr Przykowski. In his letter, he enclosed material, including photographs, which he had received the day before from Przykowski. Maddison remarks that "You will remember that I recommended him to you as a designer of sundials, and you will see from the enclosed photographs that his work is of the highest order and extremely decorative as well." He goes on to say that "As an uncommitted person in present-day Poland, Dr Przykowski's position is somewhat difficult." He adds that an invitation from abroad would make it easier for him to obtain an exit visa from Poland. He then states that "even if your project for erecting a sundial at Greenwich were of the vaguest nature...you would still do Dr Przykowski a considerable service by writing to him and suggesting that he might visit you at Greenwich in order to discuss the project." Nevertheless, Maddison follows this with the statement that "As far as I know, Dr Przykowski does not wish to revisit Britain this year but might be glad of an opportunity to do so some time next year."⁵

This implies that Przykowski had visited Britain, probably Oxford, if not Cambridge, earlier in the year 1960; but there is no record, so far as I know, that he ever came to Greenwich. David Waters might have met him abroad at a European conference; but presumably corresponded with him in the ensuing years, sending Przykowski the required plans of the ORO so that he could make the necessary calculations for his sundial designs. Quite when this occurred is unknown to me; but it could well have been about the same time that I joined the NMM. However, as a newcomer to the museum and thus a junior member of staff, I was not made aware of this scheme at the time. Furthermore, my initial duties in the museum required me to give public and educational lectures in astronomy and navigation in the planetarium, which was installed in the South Building of the ORO in the autumn of 1965. To this end, in 1964, I was sent on an astronomy course to the South Shields Marine &

Fig. 3. The drawing of the four images of the analemma by the author.

Technical College, which had an operational planetarium, with a resident astronomer on the staff. Since my principal expertise was in navigation or nautical astronomy, my first three years in the NMM were primarily devoted to acquiring a working knowledge of astronomy, rather than the study of sundials.

About the year 1965, I was allocated an office in the upper part of the west cupola in

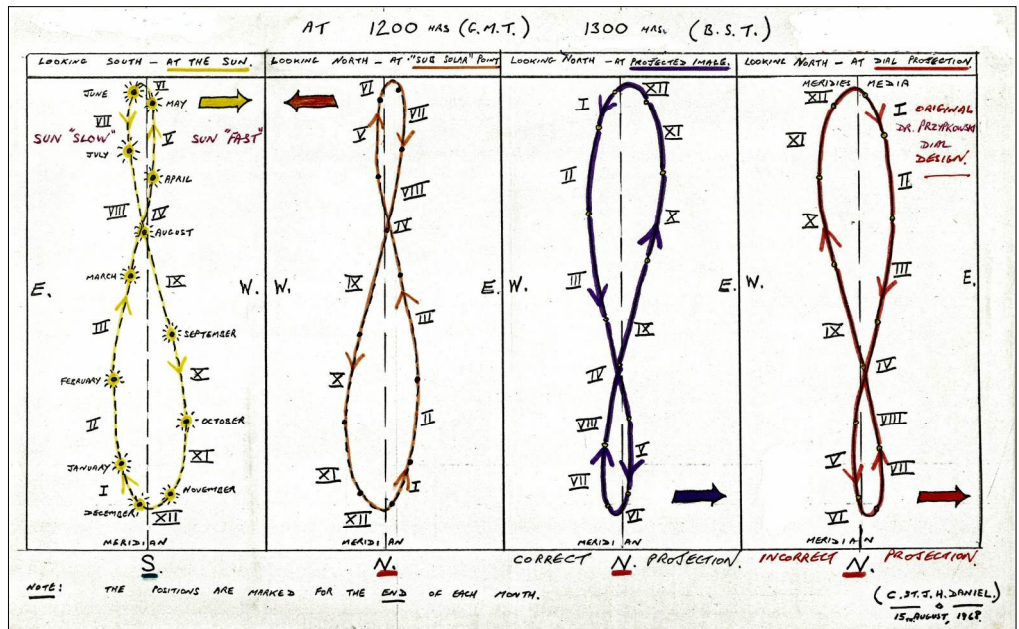
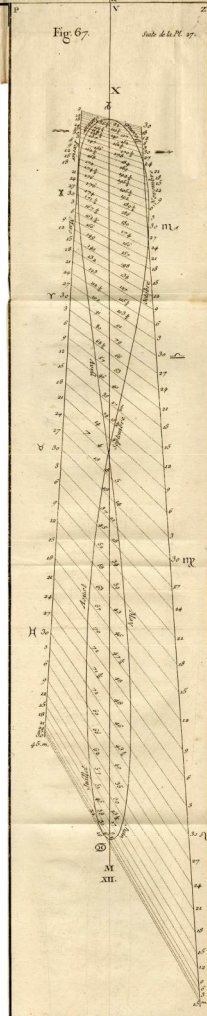

Fig. 4. Bedos de Celles: plate 27—vertical declining mean time noon dial.



Flamsteed House, being the first member of the curatorial staff to be stationed ‘up the hill’ in the ORO. It was an office with a magnificent view over the Royal Park of Greenwich and the River Thames, towards the great City of London, which was a constant source of pleasure. In 1967, when my duties included the care of the sundial and instrument displays, I found myself becoming increasingly interested in the study of the science and art of *gnomonics*, or the mathematical ‘Art of Dialling,’ as it was called in England. I was introduced to Philip Coole, the well known British Museum horological expert and an authority on long-case clocks, who became my mentor in those initial years and who wanted me to write a book on sundials.⁶ When I protested that I knew nothing about sundials, he said that that is exactly why he wanted me to write it, since I would have no preconceived ideas! Since, at this time, there was no library in the ORO and it was a long walk down to the library in the main buildings of the Museum, I had begun to collect what I considered to be useful reference books on astronomy and dialling, including the occasional antiquarian works. One of these, most probably



purchased sometime in the summer of 1968 and which was soon to prove of exceptional practical value, was a copy of *Gnomonique Pratique* by Bedos de Celles.

In 1968, I produced what might be described as my very first sundial design – for the house of a lady in Sturry on the outskirts of Canterbury – a colourful but crude drawing of a direct south dial, dated 4 June 1968. However, in this same year, I first set eyes on the sundial that had been designed by Dr Przyrkowski and it fell to me to supervise its installation. It had been specified by Przyrkowski that this sundial, (Fig. 2) as well as the others that he had designed, should be constructed in green stone or marble. Nevertheless, the Ministry of Public Buildings and Works, who carried out the construction of the dials, made them of wood, which was much cheaper. In a progress report to my Head of Department, David W. Waters, dated 27 June 1968, I stated that “The dial is now up in position” and “ready for ‘fine’ adjustment.”⁷ To this end, I was instructed to arrange a meeting with the Senior Surveyor for the following week. I cannot now recall the date or the day; but it was a pleasant summer’s morning, with ample sunshine, when, shortly before noon, Mr Davis, Senior Surveyor of the M.P.B.W, David Waters, Assistant Keeper (I) and Head of Department, Derek Howse, Assistant Keeper (I), Astronomy, and myself stood looking up at Przyrkowski’s *Meridies Media Noon Mark Mean Time* sundial.

So far as I know, neither I nor my colleagues had ever set eyes on a sundial of this kind before, which, at mid-day, employed the *analemma*, taking the form of an elongated figure-of-eight, to indicate the standard mean time of twelve o’clock, as well as the moment of true noon – when the sun is on the meridian – and the date. This was achieved by means of a *nodus*, comprising a small circular aperture at the extremity of the horizontal gnomon, fixed above the dial-plate, through which the sun’s rays were projected as a spot of light on to the dial-face. When the light spot image of the sun crossed the appropriate part of the analemma, it

would be 12 o'clock (GMT) and when it was on the vertical meridian line, it would be noon. Also, at this time, there was no other such dial known to be extant in Britain. Consequently, we were puzzled in our observations of this dial, since the reading did not appear to indicate the correct time.

Perhaps not wishing to appear ignorant by taking the initiative themselves, my seniors agreed that I should write to Dr Przytkowski and find out how the sundial worked. Bearing in mind that, at that time, Dr Przytkowski was regarded as the *doyen* of gnomonics and no doubt the most outstanding designer of sundials in the world (Fig. 5), it took me a little while to compose a suitably tactful letter, but I duly wrote to him. Prior to doing so, I carried out some preliminary research and produced a simple but somewhat crude drawing (Fig. 3) of four plotted images of the annual course of the sun, as manifest by the *analemma*, observed on the meridian.⁸ The first of these images was for an observer looking directly south at the sun, the second looking directly north at the sub-solar point, the third looking north at the projected (gnomonical) image of the sun, whilst the fourth was the dial projection according to Przytkowski's sundial drawing. I cannot recall the date when I sent the letter off; but it must have been at some time in the latter half of August, or perhaps in September. The reply came early in November 1968.

Remarkably, Dr Przytkowski had received my letter by a roundabout route. He had evidently been away from his home in Poland and had been staying in Paris, carrying out a sundial commission. My letter, it seems, had been forwarded to Paris and returned to Jędrzejów. His reply was courteous; but referred to the equation of time as if I did not really understand it, adding that "you have explanation in every handbook of cosmology" implying that I should look it up! However, he also commented that "You have reason giving in your first drawing this lemniscate looking at the sun, but in a sundial, and middle noonline is a part of a sundial, the lemniscate is in a GNOMONICAL projection as my drawing and yours the 4th!"⁹ Despite my lack of expertise in this field, I had understood that my third drawing, which depicted the projected image of the sun, was the correct one. However, I took Dr Przytkowski's advice and sought to find a 'handbook of cosmology' that would enlighten me on the subject.

I was studying my recently acquired copy of Bedos de Celles one evening, when, to my surprise and delight, I came across an illustration (Fig. 4) of a vertical, albeit declining meridian dial, which indicated mean time.¹⁰ I may not have shouted "eureka;" but here was the explanation and the proof that my third drawing was correct. Another tactful letter was sent to Dr Przytkowski, this time with a photograph of Bedos de Celles's mean time meridian dial and a photograph of Przytkowski's dial, requesting his kind explanation as to why the two were different, other than that the former was a declining dial. His reply, dated 7XII68 (7 December 1968), was an unequivocal apology – a letter typed in black and red on hand-made headed paper,

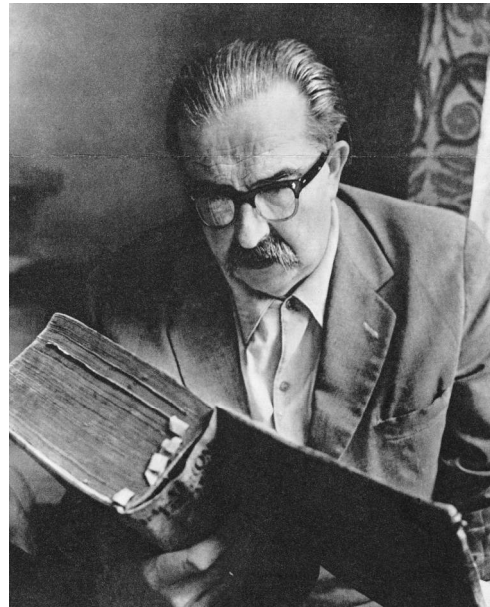

Fig. 5. Dr Tadeusz Przytkowski, acknowledged master of gnomonics.

signed with a gold ink biro. He said that his last letter to me had been written immediately after his return from France and Germany, when he was very tired, and that he had not really given proper consideration to my drawings. He had not made a vertical sundial of this kind since 1929, only horizontal mean time dials, had made this design for Greenwich in a hurry, and had made a serious mistake. He thought that "It was a very good idea of Comm. Waters to make, before the definitive execution of sun-dials, in green stone and gold, to make provisorical dials in painted wood!" He was most anxious to make amends and to recompense the Museum for the expense incurred by his error. He concluded by issuing me with a formal invitation, via the Polish Consulate, to visit him in Jędrzejów.¹¹

The following year, in 1969, the reconstructed version of Przytkowski's *Meridies Media* sundial was placed in position, adorning the south wall of the Meridian Building for some twenty-two years until 1991.¹² Due to the effects of weathering over the years and apparent storm damage, the dial was taken down, and is presumed to have been put into a builder's skip for disposal. Similarly, the other dials, which were also made of wood, suffered the same fate, despite the fact that, due to the necessity for frequent main-



Fig. 7. Dr Przytkowski outside his house and gnomonical museum in Jędrzejów, Poland.

tenance, all the painted wooden dial-plates had been fitted with protective perspex covers. However, during the period when they were on display, all of them served as a means of illustrating the fundamental use of sundials, for the purposes of determining the time from the apparent motion of the sun.

The experience of my involvement with Przyrkowski's noon sundial and my visit to Poland in the late autumn of 1969,¹³ by way of Paris, Prague and Brno, in what was then Czechoslovakia, confirmed my interest in sundials and later inspired me in my own sundial design work. Although I have written a monograph on sundials which describes Przyrkowski's instruments, this is now long out of print and quite rare.¹⁴ Likewise, I have written articles for *Clocks Magazine* on the subject; but *Clocks* circulates primarily amongst those who are clock minded.^{15,16} In the circumstances, this short historical account of Przyrkowski's noon sundial might not have been written had it not been for a recent event that brought this sundial to mind.

On the 8 June 2009, at the 'Four Liveries Lecture' held in the Instrument Makers Hall, Douglas Bateman, who is himself a Member of the Worshipful Company of Clockmakers, happened to meet Dr Gloria Clifton, Head Curator of the Royal Observatory at Greenwich, and, by chance, sat next to her at the dinner afterwards. In the course of conversation, mentioning Jill Wilson's work on sundial makers, Doug promised to send her his booklet on the DERA sundial, which he did, together with some clock articles that he had written.¹⁷ Dr Clifton responded in a letter dated 12 June 2009,¹⁸ the central text being as follows:

"Many thanks for sending me copies of your interesting papers on precision horology, and the booklet on sundials. I was particularly interested to see that the booklet includes a description of a dial which used to be at the Observatory. In fact the gnomon is still there, sometimes provoking questions from observant visitors, but I am told that the dial plate was made of some kind of plastic which cracked up after years of exposure to sunlight. Did you have anything to do with the design? If you have a copy of the photograph, it would be good to have a scan for our records, as I have not been able to track down a museum image. It would be nice to get it restored, but I imagine we would have to find a sponsor."

Doug replied to Dr Clifton's enquiry in a letter dated 17 June 2009, in which he mentions my NMM Maritime Monograph and Report No 28.¹⁹ However, it is quite

possible that Gloria Clifton's thoughts on the reconstruction of the noon sundial would have faded away, had it not been for the fact that Doug and Gloria met again at this year's meeting on 26 April. On this occasion, Doug handed her a letter, dated 26 April 2010, in which he says that, by chance, he had "found another reference to the dial in the book on sundials by Frank W. Cousins." He goes on to say

that "I enclose photocopies (from the book) which appear to claim that the design (of the noon sundial) is due to Cousins and Malcolm Chandler. The date is earlier than the reference in NMM Maritime Monograph No 28 1978 by C St J H Daniel. The latter states (p. 20) "Also designed by Dr Tadeusz Przyrkowski, Jdrzejow, Poland, erected in 1969..." He then says that "Cousins states that he and Chandler made the collage illustrated, with the photograph taken in 1968 (August)" and speculates on the status of Przyrkowski and Cousins, concerning the design of the sundial.²⁰

Fortunately, perhaps, Doug Bateman decided at this point to send me copies of his two letters to Dr Gloria Clifton. These made me realise that relatively few people knew of Dr Przyrkowski's sundials that once existed in the old Royal Observatory in the 1970s and 80s. Furthermore, I became conscious of the fact that even fewer knew that I had once

been responsible for the sundials, which were displayed in and on the buildings of the Observatory. So, I wrote to Dr Clifton to give her the basic facts and to explain the apparent misunderstanding with regard to Frank Cousins.²¹ He had visited the old Royal Observatory in August 1968, when the original noon mark sundial was still in position, and had had a photograph taken of it, with a view to including it in the book on sundials, which he was working on at the time.²² However, he was obliged co-operate with Malcolm Chandler, his illustrator, to show the sundial as it would appear, once it had been corrected – hence the photographic collage, which resembles an authentic image. The book was first published in November 1969, a glossy well-illustrated work, and the author kindly sent me a personal copy. In his correspondence, Frank Cousins not only expressed his gratitude for my "many kindnesses"; but gave me a generous credit in the acknowledgements of his book – the first such recognition that I had received in a publication concerning sundials.²³ At that time, he wrote "I often recall with much pleasure our talks at Greenwich especially our mutual interest in the Noon Mark."²⁴

Both Douglas Bateman and I have an interest in Noon Mark sundials, since both of us have designed and delineated this form of sundial ourselves, i.e. Doug's notable dial on the

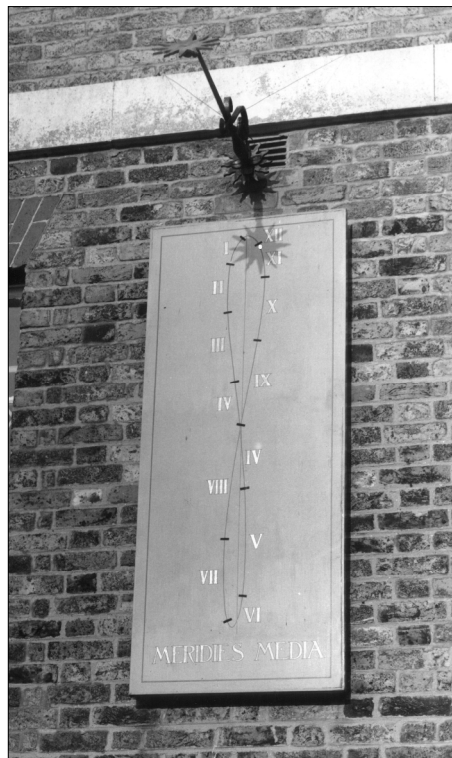

Fig. 7. The corrected wooden sundial on the Meridian building.

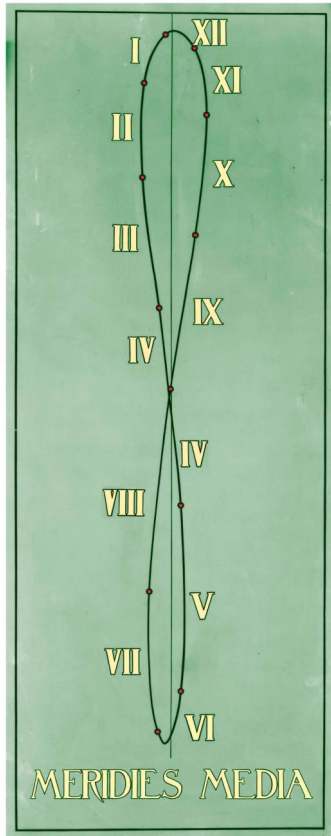

Fig. 8. *Meridies Media* – Przyrkowski's noon sundial, reconstructed in green stone, as envisaged by the author.

glass 'curtain wall' of what was then the new DERA building, in Farnborough,¹² and my dials at Green College, Oxford,²⁵ and Southfleet, in Kent.²⁶ However, Doug's chance meetings with Dr Clifton and their exchange of correspondence on the Noon Mark sundial have brought about a renewed interest in Dr Przyrkowski's sundial and the possibility of its reconstruction.

Note: The Council of the British Sundial Society has approved support for this proposed sundial reconstruction in principle, and understands that a number of its members are prepared to contribute to an official fund-raising scheme. It is to be hoped that the Membership, as a whole, will wish to be involved in restoring the Meridian Building of the Royal Observatory at Greenwich with its noon mark mean time sundial.

REFERENCES and NOTES

1. Tadeusz Przyrkowski: copy of original drawing, dated 15 November 1967.
2. D.W. Waters: *The Art of Navigation in Elizabethan and Early Stuart Times*, Hollis & Carter, London (1958).
3. A.P. Herbert: *Sundials Old and New – Fun with the Sun*, Methuen & Co. Ltd., London (1967). Foreword by Lieutenant-Commander David W. Waters, RN, FRHistS, FRAS (23 March 1965).
4. Ibid. Signed personal copy, dated "July 14 1967".
5. F. Maddison: copy of a letter to Lieutenant-Commander D.W. Waters, National Maritime Museum, dated July 8 1960.
6. P.G. Coole: copy of his letter dated 20/11/67, concerning Kathleen Higgins's article 'The Classification of Sundials', *Annals of Science*, 4(9), 15 Dec 1953, with respect to sundial nomenclature and the need for research in this field.
7. C. Daniel: memorandum to 'N.A.' (David W. Waters, Assistant Keeper, Head of Navigation & Astronomy): Progress Report (2): Meridian Building Sundial. Dated 27th June, 1968. 'NA/A2'.
8. C. Daniel: Drawing of four plotted images of the annual course of the sun, as manifest by the *analemma*, as observed on the meridian of Greenwich at 1200 Hrs (GMT) – 1300 Hrs (BST). (15 Aug 1968.)
9. Dr Tadeusz Przyrkowski: Letter, dated 31.X.68, replying to the earlier letter of the author.
10. Dom François Bedos de Celles: Pl. 27. – Meridienne Verticale du tems moyen, le plan declinant du midi vers l'orient de 42

- degrés 36 minutes; *La Gnomonique Pratique, ou l'Art de Tracer Les Cadrans Solaires*, first published in Paris in 1760.
11. Dr Tadeusz Przyrkowski: Letter, dated 7XII68, apologising for his mistake, seeking ways to recompense the National Maritime Museum and inviting the author to visit him in Poland.
12. D. Bateman: *Sundials in DERA*, DERA (2000).
13. Author's passport: Ceskoslovenske visa 1969, CSSR arrival stamp: Praha 21.10. – departure 26.10. Polskiej visa 1969, arrival stamp: 26.X.1969 – departure : 02.XI 1969.
14. C. Daniel: *Sundials on Walls*, National Maritime Museum: Maritime Monographs and Reports No. 28 (1978).
15. C. Daniel: 'Poles apart', The Sundial Page, *Clocks Magazine*, 25/8 (Sep 2002).
16. C. Daniel: 'Polish heritage', The Sundial Page, *Clocks Magazine*, 25/9 (Oct 2002).
17. D. Bateman: e-mail dated 15 June 2010.
18. G. Clifton: Copy of her letter to D. A. Bateman, dated 12 June 2009.
19. D. Bateman: Letter to Dr G Clifton, 17 June 2009.
20. D. Bateman: Letter to Dr G Clifton, 26 April 2010.
21. C. Daniel: Letter to Dr G. Clifton, 30 April 2010.
22. F.W. Cousins: *Sundials – A Simplified Approach by Means of the Equatorial Dial*, illustrations by Malcolm Chandler, John Baker, London, (1969).
23. F.W. Cousins: Letter to the author, 1968 Dec 26.
24. F.W. Cousins: Letter to the author, 1969 November.
25. C. Daniel: 'Figures-of-eight', The Sundial Page, *Clocks Magazine*, 19/5 (Oct 1996).
26. C. Daniel: 'A practical instrument', The Sundial Page, *Clocks Magazine*, 22/12 (Dec 1999).

Beautifully Crafted Replicas of
PORTABLE DIALS
 at Affordable Prices

**IVORY
 DIPTYCH
 DIAL**

The traditional type of dial produced in Nuremberg around 1600. This is a replica of a dial made by Hans Troschel in 1626. It carries individual scales for Italian, Babylonian and Planetary Hours. On its lid is a Lunar Volvelle.

Complete with a blue simulated leather carrying case.

Hand made and painted on ivory resin.

Order Code LH-A112
 Price £105 inc VAT

GREEN WITCH
 www.green-witch.com
 01767 677025
 Greenwich House, 2 Bakers Court,
 Great Gransden, Sandy, Bedfordshire SG19 3PF

Please Note our New Address

BSS NEWBURY MEETING—25 September 2010

Mike Groom

Saturday the 25th of September saw a bright if chilly day, when 36 members, seven of whom were attending for the first time, gathered at Mary Hare School for the 2010 BSS Newbury Meeting.

There were many old and new friends and a good number of exhibits generating numerous animated conversations. Peter Ransom as master of ceremonies used his well-honed classroom skills to quell the hubbub and introduce the morning's short talks on schedule.



This reporter (left) listens to the MC for the day, Peter Ransom

To begin, John Davis described his initial research into the first appearance of 'scientific' sundials in Britain, that is the transition from Saxon unequal hour dials to equal hour dials with a polar gnomon. His research was prompted by reading a statement that modern dials first appeared in England in the 14th century. So far his quest has shown a good number of dials from the 16th century. One was a dial from c.1560 at Sutton Hall, Suffolk which has been beautifully restored by Harriet James. The earliest dial so far identified is a pre-15th-century(?) vertical ceramic dial from St. Augustine's Abbey, Canterbury.

The oldest reliably dated polar-gnomon dial in the world, by Ibn al-Shatir in 1371, is a horizontal dial on a window sill high above the central courtyard of a mosque in Damascus. The Islamic tradition of equal hour dials is significantly earlier than the European: John showed a vertical dial from 1463 on the Jacobi Church in Utrecht. He then presented evidence that the knowledge of scientific dials was being disseminated throughout Europe and into Britain during the 15th century by monastic scribes; a task greatly facilitated by the

common use of Latin. It is not clear that this knowledge had originated in the Arab world as the monastic texts employ geometric construction whereas the Islamic texts relied on tables of coordinates.



Next was a double act from Essex describing the restoration of two Essex Dials. David Young told us about the restoration of the dial that had fallen off a church at Southminster. This was a massive painted metal dial on a wooden back board. In spite of falling from a great height and being stored in less than ideal conditions, the brass plate required only a little straightening and a good clean. Once fixed on a new wooden board and with re-painted numbers and lines it was re-mounted with considerable physical effort. For some reason the picture of the Vicar, with a broad smile, next to the restored dial, shows that she chose to climb the scaffolding barefoot. (But then she does answer to a higher authority than the HSE.)



The second restoration was described by Ian Butson and concerned an unusual wooden dial carved in relief on the church at Nazeing. In fact the dial was a total replacement; the original is on display inside

the church. It was carved from solid chestnut boards. There was no painting; the plain wood was treated with numerous coats of linseed oil.



The last talk of the morning, 'Notes from the South West' by Martin Jenkins, was an interesting ramble around a number of dials in Devon and Cornwall. It started with a very large vertical dial on the gable end of a Lutyens house. The dial was also designed by Edwin Lutyens. (Apparently we can expect to hear more about Lutyens as a sundial designer, as this is a subject being researched by John Foad.) From this we were led through a whole series of dials by a number of strange coincidences that included a floating barometer. The last but one stop was at a dial in the garden of a former vicarage not far from Janet and Martin's house. It was an impressive horizontal metal dial on a stone plinth, in the form of a cube dial – sadly without gnomons. There was general discussion concerning the apparently meaningless cod Latin inscriptions. The trail finished back at their garden with a picture of a dial by Ben Jones covered in last winter's snow.

Kevin Karney reported that the *Bulletin* index was progressing; he asked for further volunteers and people interested in purchasing a copy when it becomes available. Before dismissing the class Peter Ransom congratulated John Davis on the production of the blue 75th edition of the *Bulletin*.

Michael Maltin expressed the sentiment of the meeting by thanking David Pawley and Wendy for their organisation.

David took the opportunity to ask if anyone could remember when the first Newbury meeting was held. As no opinion was forthcoming it was left open that this was



Tony Belk (chairman of the Sundial Design Competition judges - see p. 45) shares a joke with our Vice-President David Young.



Our organiser David Pawley explains how to fix a dial to a flint wall



either the 14th or 15th gathering. He said that this would be the last meeting at Mary Hare School as a result of tighter security requirements and that he is actively seeking a nearby alternative for next year. David has also expressed his thanks to Janet Jenkins for the production of the flyer.

gress. The same base mechanism will be adapted to produce a version of one of A.P. Herbert's dials.

Also on display was a collection of paper dials made by Peter Lamont and purchased by David Brown at a BSS auction and a very pleasing glass dial by George Higgs and David Gulland.



The lunch break allowed adequate time to browse the bookstall and look at the exhibits. These included demonstrations in real sunshine of Doug Bateman's corner cube and Michael Maltin's similar devices for determining the direction of the sun. John Davis had an excellent reproduction of a 1688 Richard Whitehead horizontal dial with an unusual vertical rod gnomon for the azimuth readings in addition to the normal polar gnomon. Michael Lee's display included a very impressive equatorial dial in etched brass. It is still a work in pro-

After the lunch break there was the group photograph (see front cover) followed by the final talk of the day. This was by Peter Ransom and described some of his recent purchases and was titled 'Two dials, two books and two stamps'. The first dial was the simple acquisition of a nice horizontal stone dial. The second was carved onto the top face of a massive York stone plinth. The logistics of transporting this monolith were similar to those used by the builders of Stonehenge except that they did not have the use of Peter's wife's car. The first of the two books was an edition of Gatty. What was particularly interesting was the inscription showing that it was given to a Sir Dighton Probyn in 1907 by "George P. and Victoria Mary". Research showed that this was Prince George, later George V and that Sir Dighton was a hero of the Indian Mutiny and long serving head of the Royal Household. The second book was a miniature book of sundials intended for the library of a dolls house. Finally Peter showed two sheets of stamps issued by the DDR, one showing a sundial and the other a clock, very generously he gave one to everyone present.

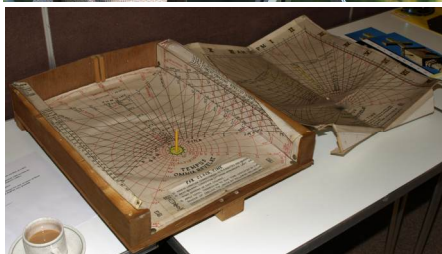

Above: Michael Maltin with his meridian device; two of the complicated dials by the late Peter Lamont, being cleared from David Brown's attic. Left, top to bottom: a reproduction Richard Whitehead dial under construction by John Davis; an early Scottish slate dial brought along by David Brown; a memorial to a Spitfire pilot by David Hawker; part of one of Mike Lee's distinctive dials; Doug Bateman and Kevin Karney setting up a meridian watched by Colin Davis.

The final activity was David Pawley demonstrating the application of gold leaf transfer to the cast iron dial of a tower clock which he is currently restoring.

It was agreed that this was another excellent meeting and everyone was looking forward to next year at a new venue.

Author's address:
home@mjgroom.com

Photos from John Davis and Ian Maddocks.

THE PERCEPTION OF TIME IN ANGLO-SAXON ENGLAND

DAVID SCOTT

Most of the evidence for time-reckoning in Anglo-Saxon England is in the form of the stone sundials which have survived in considerable numbers to the present day. They have been catalogued and studied in detail,¹ but it is still not known for certain how they were used, or indeed how the Anglo-Saxons experienced the abstract notion we call time. There are, however, a few manuscripts from the period which give some idea of how they perceived the passage of time, and the varying importance they attached to it, although interpretation of the evidence is sometimes difficult.

Heathen Time-Reckoning

At the beginning of the seventh century, before the coming of the Christian missions to England, the heathen Anglo-Saxons had no written calendar or system for dividing the day into equal intervals. Time probably appeared as a recurring cycle of familiar natural events, and direct observations of the sun and moon's positions were used as markers for the divisions of time. The year began at the winter solstice and was divided by the periods of the moon, each associated with a particular agricultural activity and devoted to one of their pagan gods. The last month of the old year and the first one of the new year were combined together and known by the name *Giuli*, the meaning of which is unknown but it has come down to us as *Yule*. Similarly, the sixth and seventh months were linked together, spanning the summer solstice, and were known by the name *Litha*, which meant navigable because in those months the breezes were gentle, but there is no known modern equivalent for this word.² The counting of moons was common – three months for each season, six months between sowing and harvest, and nine months for a pregnancy. Such facts were easily ascertained and important to know. The day was defined by dawn and dusk, which can be determined in all weather conditions, and when the sun was shining they probably used the age-old method of taking the sun's position over a prominent local landmark as a reference for the time of day.

Early Christian Time-Reckoning

It was the Christian missions to England who first introduced systematic time-reckoning. They had a written calendar but needed to be sure of the day on which the spring equinox occurred, for on it depended the date of Easter and the other Church Festivals. They also needed a method of marking the times in the day decreed by the Church for services in monasteries.

Bede (674-735) said that the date of the spring equinox could be confirmed as 21 March by consulting a horolo-

gium.³ But the accumulated error in the Julian calendar used by the Church, if uncorrected, would mean that the spring equinox early in the eighth century would occur on 17 March and not 21 March.

According to the Julian calendar, introduced in Rome in 46 BC and intended to correct the errors of earlier calendars, the spring equinox occurred on 25 March. But the mean length of the year by the Julian calendar was 11 minutes and fourteen seconds longer than the solar year and this difference, although small, amounted to several days after a few centuries, placing in doubt the date of the spring equinox and thus the date of Easter and the other Church festivals. The problem was discussed at the General Church Council held in 325 AD at Nicea, west of Ankara, and it was decided that by the Julian calendar the spring equinox occurred on 21 March, and this was the date used by the Christian missions to England for calculating the future dates of Easter.

Bede did not describe the type of horologium used, but it may have been the one illustrated in the *Computus* which had been inserted in the *Psalter* manuscript from the early eighth-century monastery at Echternach, north-west of Trier, founded by Willibrord (658-739) the Northumbrian missionary to the continent, (Fig. 1).^{4,5} A *Psalter* was a

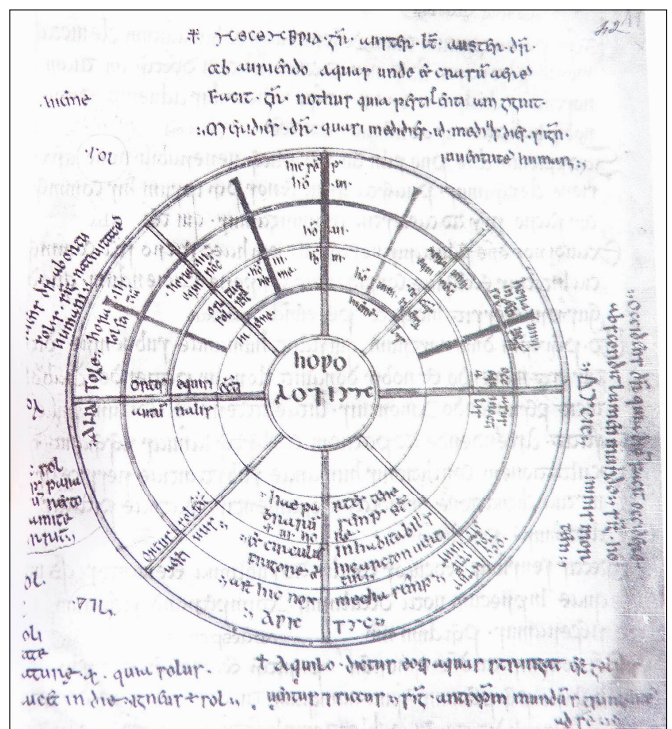

Fig. 1. The Sun-Path Horologium. From *The Calendar of St. Willibrord*, MS Paris Lat. 10837. See also Ref 5.

book of Psalms, especially as arranged for devotional use, and the *Computus* a collection of brief notes, tables and diagrams, usually by different authors, on the calendar, and methods for calculating the future dates of Easter.

The horologium was marked out on the ground and oriented north-south, and believed to have been about six metres in diameter. An observer standing at the centre could note the occurrence of the solstices from the extreme positions of sunrise and sunset on the horizon, but they are uncertain in terms of days and unsuitable for checking dates. Knowing that the spring equinox occurred at the mid-point between the solstices, the observer could anticipate the event and wait for the day when sunrise, the observer, and sunset were in the same straight line. On that day the date should be 21 March, and if it was not then the calendar was adjusted accordingly. It takes rather more than one hundred years for the error in the Julian calendar to accumulate to a whole day, and no doubt over the centuries the Church had from the time of Nicea made checks to confirm that the spring equinox and the calendar date were not drifting apart, making adjustments as necessary. This would explain how Bede was able to state correctly that the date of the spring equinox could be confirmed as 21 March, i.e. by consulting a horologium. The sun-path horologium also enabled the monasteries to reckon in equinoctial hours. Taking the circumference of the circle as representing the twenty-four equinoctial hours of day and night together, it was a simple matter to count the hours between sunrise and sunset, and thus to determine the lengths of day and night for each month of the year, which was often added to the bottom of the calendar for each month.

The problem of the error in the Julian calendar was not resolved until 1572 when Pope Gregory XIII introduced a revision to correct the date. It was ordained that the day after 4 October should be called 15 October, in order to restore the spring equinox to 21 March. At the same time the arrangement for adding leap-year days was changed to eliminate the error, and the beginning of the New Year changed from 25 March to 1 January. In Britain the Gregorian calendar was not officially adopted until 1752 by which time the error amounted to eleven days.⁶

The other time requirement in monasteries was marking the Canonical Hours decreed by Church Law for prayers. They originated with Psalm 119:164 which states “Seven times a day have I praised thee because of thy righteous judgements”, and this was included in the Rule of St Benedict in England, at least in the modern version,⁷ as “We will fulfill this sacred number of seven if we satisfy our obligation of service at Lauds (daybreak), Prime (sunrise), Tierce (the third hour), Sext (the sixth hour), Nones (the ninth hour), Vespers (sunset), and Compline (nightfall).”

The monastic communities, and possibly the bishops and attendant clergy, thought of the day between sunrise and sunset as divided into twelve equal intervals (‘seasonal’ or ‘temporary’ hours). When Theodore (602-690) came from

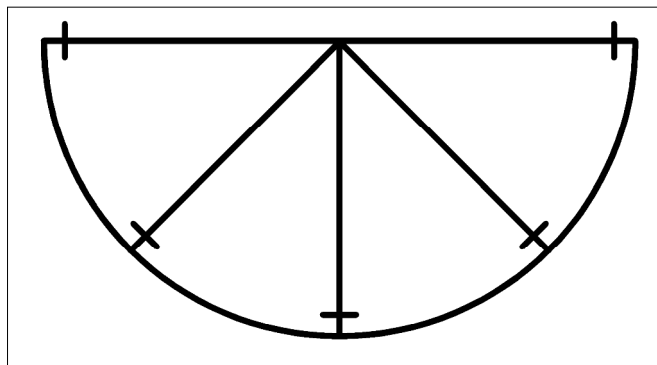

Fig. 2. Drawing of a typical Anglo-Saxon monastery dial.

Rome to England as archbishop of Canterbury after the Synod of Whitby, charged with placing the Anglo-Saxon Church on an organised basis, he may have instructed the monasteries to standardise the times for celebrating the canonical hours, to ensure that all Christian communities were following the same Rule. It was possibly for this purpose that the monastery sundial, Fig. 2, first came into use. The diagram depicted the daylight period, but did not mark equally spaced points in the day throughout the year, with the exception of the sixth hour, midday. Some diagrams were more accurately laid out than others, they were better pieces of sculpture but not better sundials, for the abbot was concerned with the discipline of the monks and not precision in time-keeping, and the dial served as a reminder of the monks’ obligation in all weathers.

During the seventh and eighth centuries the monasteries in England, particularly in Northumbria, became renowned centres of Christian learning, but the early zeal did not last. Already early in the eighth century Bede had noticed how great was the falling-off of the spirit of Northumbrian religion, and how much less the clergy were respected.⁸ The Viking invasions of the ninth century when the monasteries at Jarrow and Lindisfarne were destroyed must have been a severe setback for the English Church.

Later Monastic Time-Reckoning

During the tenth century there was a monastic revival in England, under the influence of teachers not from Rome but from Fleury in France, and centred in the southern part of the country. Byrhtferth (960-1020) a monk and teacher at Ramsey Abbey, north-west of Cambridge, and a pupil of Abbo the most learned among the monks at Fleury, compiled a Psalter with a lengthy section on the computus.⁹ The fate of the original manuscript is unknown, but a copy made for the neighbouring abbey at Thorney survives as Thorney Manuscript 17 in the library of St John’s College in Oxford. One page, shown in Fig. 3, illustrates a device for telling the hour of the day from the length of a standing person’s shadow. It was based on the assumption that the ratio of a person’s height to the length of their feet was a constant, which it is more or less. The table of shadow lengths and times could be used by anyone, including nuns who were generally shorter and had smaller feet. The drawing suggests that the device was made in two parts so that the upper half could be turned to reveal the details for a particular

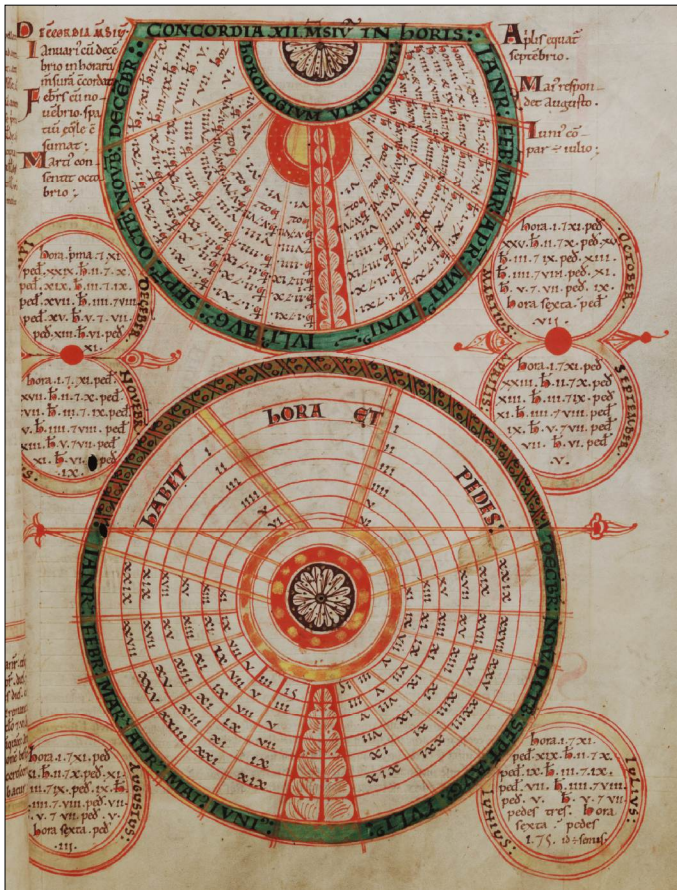

Fig. 3. The Shadow-Length Horologium. Copyright St John's College, Oxford, Thorney MS 17 f.37r.

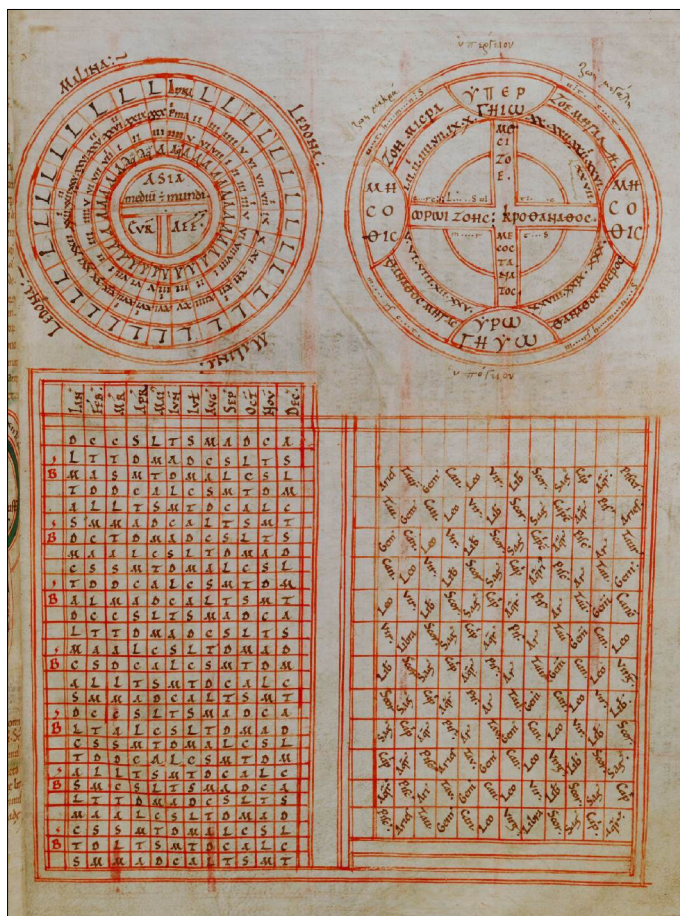

Fig. 4. The Sphere of Apuleius Tables. Copyright St John's College, Oxford, Thorney MS 17 f.8r.

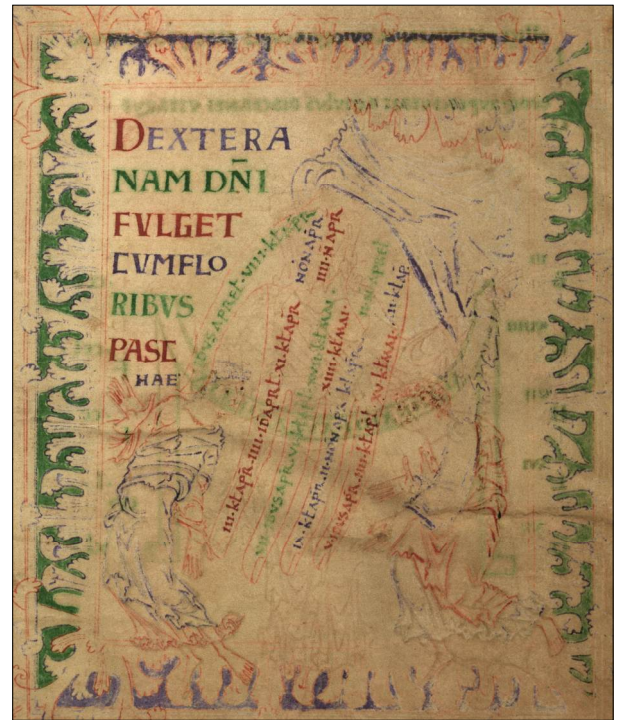

Fig. 5. The Paschal Hand. Copyright Bodleian Library, Bodl. 579 f.49r. Also redrawn in Ref. 12.

month, and the name *Horologium Viatorum* suggests that it was intended for use while away from the monastery. The shadow lengths and times were only approximate, similar to the wall-mounted sundial and serving a similar purpose.

Another page in the Thorney manuscript (Fig. 4) consists of two schematic circles with accompanying tables representing a device known as the Sphere of Apuleius. This was an ancient formula for predicting the outcome of an illness, whether a patient would live or die. It was known and used all over Europe and easy to handle, and was based on the magical properties of numbers. All one had to do was add together the numerical value of the letters of the patient's given name, to which was added the day of the moon on which the patient fell sick. The total was divided by thirty and if the remainder was found among the numbers in the circle representing the upper half of the sphere it meant that the patient would live.^{10,11}

A second manuscript from the period, Oxford Bodleian Library Bodl. 579, known as *The Leofric Missal* after Leofric who came to England from France before the Norman Conquest and became the first bishop of Exeter between the years 1050 and 1072, is a Mass Book to which was added an English computus.¹² It includes a drawing showing a hand emerging from the clouds on which are details for calculating the date of Easter, (Fig. 5). Also are included a table of shadow lengths for the third, sixth and ninth hours, and drawings of *Vita* and *Mors*, the personifications of good and evil, each holding sashes displaying the numbers used in the Sphere of Apuleius formula for predicting the outcome of an illness (Fig. 6).

The third manuscript, and perhaps the best as an indication of how time was perceived in the monasteries during the latter part of the Anglo-Saxon period, is the *Psalter Cotton*

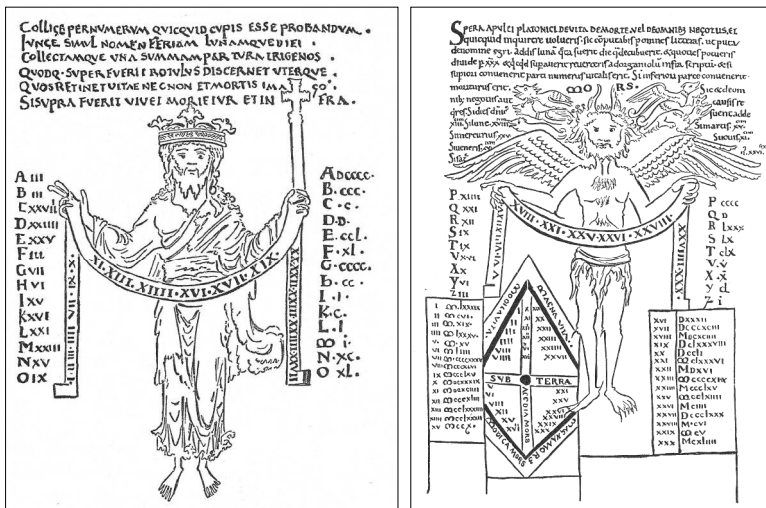

Fig. 6. Figures of Vita (left) and Mors (right). From Ref 12, redrawn from Leofric's Missal, Bodleian Library, Bodl. 579 f.49v and 50r.

All monastic life was imbued with religious connotations, and the drawings may have been inserted in the Psalter as reminders to the monks of their obligation to observe the canonical hours, and to celebrate Easter on the proper date. And that all aspects of time – the hour, the day, the month, the year, human life, and the life of the universe – were in the hands of God.

This might have been the symbolism behind the design of the sundial at North Stoke in Oxfordshire, illustrated on the front cover of Ref. 1 [shown in the review in *Bull* 22(ii), p.9, Sept. 2010].

Tiberius C vi now in the British Library. It was made in Winchester around the year 1050, but was damaged by fire in 1731 in the library of Sir Robert Cotton, its former owner who died in 1631, and has shrunk unevenly.

One page (Fig. 7) shows God holding the world in his hands, illustrating the first day of creation as described in the book of Genesis. On the reverse side is a drawing (Fig. 8) encribed horologium which looks like a sundial but it is not known if the illustrator used a dial as his model or whether it is an artist's impression. It does confirm that the monasteries divided the day between sunrise and sunset into twelve equal periods, and continued to place special importance on the third, sixth and ninth hours. The small crosses before sunrise and after sunset probably represented Lauds and Compline which cannot be marked by a shadow, but with sunrise and sunset, and the third, sixth and ninth hours, make up the seven canonical hours of the Benedictine Rule.

Under the horologium drawing is an inscription which in translation reads "The right hand of God is bright with the flowers of Easter",¹³ referring to the drawing below, only faintly visible but similar to Fig. 5 in the Leofric Missal, but in this instance the hand is emerging from a sleeve. On an adjacent page the figures of Vita and Mors are shown one above the other.

Time-Reckoning in the Villages

Monastic and village communities probably perceived the passage of time in different ways, at least in the early centuries of the Anglo-Saxon era: to the monasteries time was a manifestation of God's will, to the lay population merely an aspect of nature.

The regular sound of the bell used by the monks to inform the monastery that the canonical hours, as indicated by the sundial, were imminent, could be heard by the villagers working in the fields. No doubt they found these time-markers useful for dividing their own days, and when the parish churches acquired their own bells they may have copied the monastery sundial to mark the by now familiar points in the day. In due course they found it an advantage to sub-divide the intervals, giving rise to the eight-division sundial (Fig. 9) unrelated to hourly divisions.

Most of the surviving Anglo-Saxon sundials are from the latter part of the period, and the variety of designs suggests that the makers were uncertain about what they were trying to depict. The parish church bell would have been used for weddings and funerals, and the special mark on the sundial below the horizontal on the left hand side may have indicated the time for morning mass, each function of the bell being recognised by the different pattern of sounds.

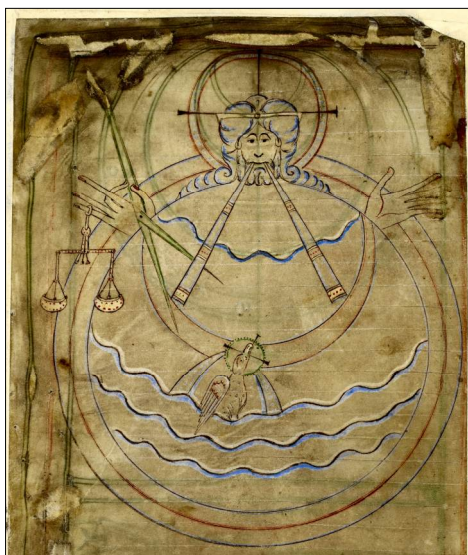
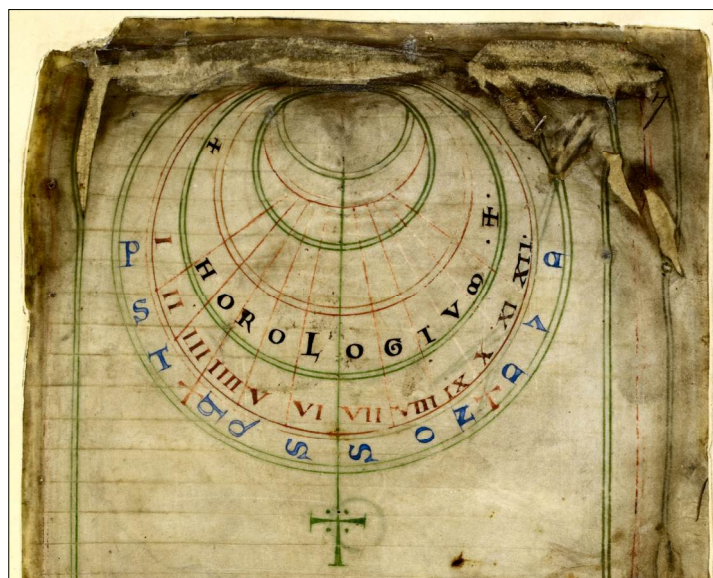

Fig. 7. The Creation. By permission of the British Library, MS Cotton Tiberius C vi f.7r.

Fig. 8. The Horologium. By permission of the British Library, MS Cotton Tiberius C vi f.7v.



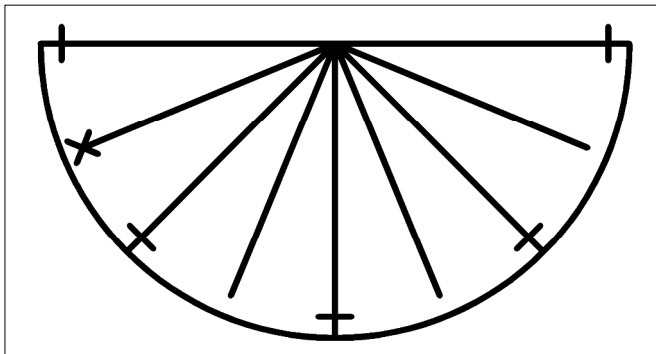

Fig. 9. Drawing of a typical parish church adaptation of the monastery dial.

Many of the parish priests were but poorly educated, at least Byrhtferth thought so when he wrote his book *The Enchiridion* intended for the instruction of rural priests in the course of their duties.¹⁴ He mentions the ‘daegmaele’ which may have been the name for the parish church sundial marking divisions of the day, as distinct from the monastery ‘horologium’ which marked seasonal hours. The parish church bell served a purpose similar to the later public clock, but at that stage unrelated to numbered hours.

It must have been realised that the time marked by the mass-line on the sundial was not consistent throughout the year. The ‘mass dial’, also known as a scratch dial due to the way in which it was made, is usually associated with the post-Conquest period. But it may have been introduced towards the end of the Anglo-Saxon period, perhaps by Byrhtferth, when the parish priest was shown how to insert a pin in the south-facing wall of the church, and when he judged the time from the position of the sun scratched a line over the shadow. If this exercise was repeated in winter, spring/autumn, and summer, there would be three different lines. This rule of thumb method, although more accurate than the Anglo-Saxon sundial, might explain why there are so many scratch dials in the country with sometimes more than one on the same church.

The villagers would not have known about the Sphere of Apuleius formula for predicting the outcome of an illness, and the priest would have worked it out for them, sometimes turning out to be correct and sometimes not, but it would have been a further example of the hold he had over their lives.

The methods of time-marking used during the four centuries of the Anglo-Saxon period – the sun-path horologium, the monastery sundial, the shadow-length horologium, the parish church adaptation of the monastery sundial, and the mass-dial – probably all continued in use, to a greater or lesser extent, until finally rendered obsolete by the successful development and ready availability of the mechanical clock.

ACKNOWLEDGEMENTS

My thanks to John Davis for obtaining original copies of some of the figures, Mike Cowham for figures 2 & 9, and to Denis Schneider for Fig. 1.

REFERENCES

1. D. Scott & M. Cowham: *Time Reckoning in the Medieval World*, BSS Monograph No. 8 (2010).
2. Sir Frank Stenton: *Anglo-Saxon England*, Oxford University Press (1971)
3. Faith Wallis: *Bede: The Reckoning of Time. Letter to Wicthed*, Liverpool University Press (1999).
4. Barbara Obrist: ‘The Astronomical Sundial in St Willibrord’s Calendar and its Early Medieval Context’, *Archives D’Histoire Doctrinaire et Litteraire du Moyen Age*, 67, 71-118 (2000).
5. H.A. Wilson (Ed.): *The Calendar of St Willibrord. From MS Paris Lat. 10837. A Facsimile, with Transcription, Introduction and Notes*. The Bradshaw Society, 1918; reprinted The Boydell Press, Woodbridge, 1998.
6. Sir Harold Spencer Jones: *History of Technology. 21 - The Calendar*, Oxford University Press (1950).
7. Timothy Fry: *The Rule of St Benedict*, The Liturgical Press, Collegeville, Minnesota, USA (1982).
8. Leo Sherley Fricke: *Bede: Ecclesiastical History of the English People*, Penguin Books (1990).
9. Peter S. Baker: ‘Byrhtferth’s Enchiridion and the Computus in Oxford, St John’s College 17’, *Anglo-Saxon England*, 10, 12.3-142 (1982).
10. Adelheid Heimann: ‘Three Illustrations from the Bury St Edmunds Psalter and their Prototypes’, *Journal of the Warburg and Courtauld Institute*, 29, 39-59 (1966).
11. Francis Wormald: ‘An English Eleventh-century Psalter with Pictures’, *The Walpole Society*, XXXVIII, (1960-62).
12. F.E. Warren: *The Leofric Missal*, Oxford University Press (1883).
13. Dr M. Brown (British Library): private letter (2004).
14. Peter S. Baker & Michael Lapidge: *Byrhtferth’s Enchiridion* Oxford University Press (1995).

Author’s address:
26 Barrswood Rd,
New Milton
Hants., BH25 5HS

MERTON COLLEGE DIAL

This dial (SN0583) with ‘criss-cross lines’ (see page 9) is on the east side of the last buttress of the chapel at Merton College, Oxford. It uses a simple nodus on an adjacent buttress to cast a shadow.

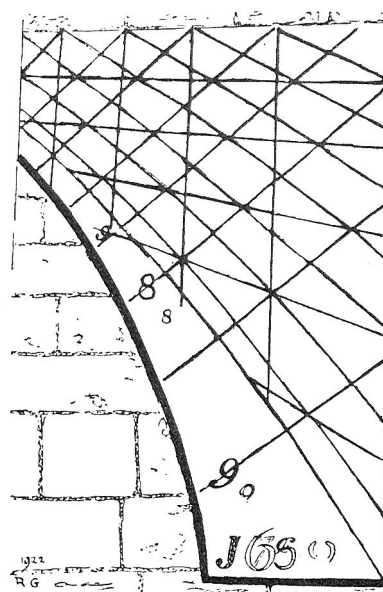

The date is problematic but it was probably originally made in 1629 or 1659 (though Pugin shows 1622) and re-dated at a later restoration. The designer was probably either Jo. Bainbridge (master-commoner at Merton) or the mathematician Henry Briggs.

This 1922 drawing is by Robert Gunther from his *Early Science in Oxford*, Vol. II. He records an extension of the dial on the south side but this is no longer visible.

JD

BEATA BEATRIX

ROGER BOWLING

Sundials do not often appear in fine art, paintings, drawings or illustrations, but when they do they usually symbolise nothing more than the passage of time. But there was one painter whose sundials symbolise much more, and are an important part of the picture.

That painter was Dante Gabriel Rossetti. His picture, *Beata Beatrix*, (Fig. 1) in the Tate Gallery, with five replicas elsewhere, is one of the most popular paintings in this country. Most people on seeing it wonder what the sundial is supposed to represent, and wonder why the shadow is on the hour nine. Only members of the BSS will notice that the dial is nonsense, the gnomon appears to point south and the shadow on the hour nine is in an impossible position. They will have asked themselves why; are these just mistakes, or is there some deep hidden meaning. The first member to ask this question in these pages was Denis Schneider.¹ I too asked these questions and set out to find the answers.

It took a long time and is a complicated story. I also found that *Beata Beatrix* is not Rossetti's only sundial painting: including studies, there are ten more, and all but two are in pictures telling part of the same story. It is a love story between Dante the medieval Florentine poet and his ideal of pure love, Beatrice. But the painting is also, in part, the story of Rossetti's doomed affair with his muse, mistress and wife, Lizzie Siddal.

So let me introduce the two pairs of lovers.

Dante Alighieri (1265-1321) and Beatrice Portinari (1266-1290)

Dante was a poet, soldier, politician, and outlaw. He attained high public office in Florence but backed the wrong side in one of the civil wars, was exiled and sentenced to death if ever returning to Florence. Dante and Beatrice were both born in Florence, they were almost the same age and lived close to each other. They first met at a May festival when they were both nine years old. Nine years later they met again as Beatrice was walking with her girl friends. She greeted Dante but he doesn't say what she said, and it appears that they never spoke to each other again.

From that time on Dante was besotted with her, though she never returned his love, married another, and died in 1290, aged twenty four. In his poem *La Vita Nuova*, (best translated as 'poems of youth'), he describes his early life, their two meetings, his love for Beatrice, and his feelings after her death. The work is really a selection of his early poems and it also contains his commentary about the piece, the events that made him write the poems, and his emotions at the time, mixed with an explanation of the structure of the

poem. He used the poem as a test piece, passing it around to his friends, the other Florentine poets, and seeking their opinions: they were favourably impressed. It is this poem that provides the explanation of the painting, *Beata Beatrix*.

At the end of the poem, after the death of Beatrice, he describes a vision which made him decide that until he was worthy enough to do so, he would write no more concerning Beatrice. When he does, the result is the long poem, *The Divine Comedy*. In this he describes journeying with his spirit guide Virgil through the Inferno, meeting Beatrice again in Purgatory, and entering Paradise together.

Dante Gabriel Rossetti (1828-1882) and Elizabeth 'Lizzie' Siddal (1829-1862)

Rossetti, poet, translator and scholar of the medieval Italian poets, is best known as an artist. His father, also called Gabriel, was a political refugee from Naples, professor of Italian at University College, London, and also a Dante scholar. It would have come as no surprise that Rossetti was named Gabriel Dante, but about aged 20 he rearranged his names to Dante Gabriel to stress his vocation of poet, and some say a better poet than artist. In 1848, with other young artists, sculptors and critics, he formed the Pre-Raphaelite Brotherhood which shook up the art world for a very long time.

They attracted a group of young ladies around them, although one or two were not quite 'ladies'. They became their muses, models, mistresses and wives. Several were talented poets and artists in their own right. When Rossetti met the young lady Elizabeth 'Lizzie' Siddal, he idealised her as his Beatrice and she modelled almost exclusively for Rossetti for many of his early paintings from about 1850. Their affair didn't last: for five years they were estranged, but in 1860 they married, rather against the wishes of their friends, although they thought the marriage not too bad a thing as it meant that only two lives were ruined rather than four. The friends were right.

Lizzie, certainly for all the time she knew Rossetti, suffered from some never-diagnosed malady – TB and anorexia have been suggested. She died by an overdose of laudanum (an alcoholic tincture of opium). Suicide was suspected but the verdict was accidental death. She had suffered one miscarriage and may have feared another. Her death was the stimulus that eventually produced the picture *Beata Beatrix*.

The Painting

If trying to explain the meaning of any Rossetti painting, there are two things to remember. First, that every object in the painting is meant to be there – nothing is there to balance the picture, to fill up space or use up left-over paint.

Secondly, every object portrayed is really symbolic of something else so it gets complicated. In this painting, as one critic put it, “the iconography is dense”.

There should really be no better explanation of the painting than Rossetti’s own, and this he provided in a letter to the Hon Mrs Cowper-Temple in 1871.² It was Mrs Cowper-Temple who gave the painting to the Tate Gallery.

“It must of course be remembered, in looking at the picture that it is not at all intended to represent death...but to render it under the resemblance of a trance, in which Beatrice seated at the balcony overlooking the city is suddenly rapt from Earth to Heaven. You will remember how much Dante dwells on the desolation of the city in connection with the incident of her death, & for this reason I have introduced it, as my background, and made the figure of Dante and Love passing through the street & gazing ominously at one another, conscious of the event, whilst the bird, a messenger of death, drops a poppy between the hands of Beatrice. She sees through her shut lids, is conscious of a new world, as expressed in the last words of the *Vita Nuova* ‘Quella beata Beatrice che gloriosamente mira nella die colui est per omnia saecula benedictus’ (‘that blessed Beatrice who now gazeth continually on His countenance who is blessed throughout all ages’).”

He makes no mention of the sundial or the figure nine, but, in a letter to one of his clients, Ellen Heaton, in 1863, Rossetti writes;³

“You probably remember the singular way in which Dante dwells on the number nine in connection with Beatrice in the *Vita Nuova*. He meets her at nine years of age, she dies at nine o’clock on the ninth of June, 1290. All of this is said, and he declares her to have been herself ‘a nine’, that is the perfect number, or symbol of perfection.”

Notice that Rossetti says “she dies at nine o’clock”, (am or pm?) but, just to make sure, let us see what Dante himself said about the death of Beatrice. This is in the

Vita Nuova, Canto XXIX, here in the medieval Italian;

“l’anima sua noblissima si parti nella prima ora del nono giorno del mese.”

And to make absolutely sure here is Rossetti’s own translation of the above line;

“her most noble spirit departed from among us in the first hour.”

So where does the modern version of the story that Beatrice died at nine come from? I asked two experts if they could transcribe, ‘the first hour of the ninth of June, 1290’, into modern parlance.⁴ Both said it was a difficult problem, depending on the time system in Florence at that time: was it the Italian equal hours system or the earlier canonical hours system – it could have been either. But one of my expert friends discovered that Dante himself had described the systems in use in his time. It appears in his long prose-

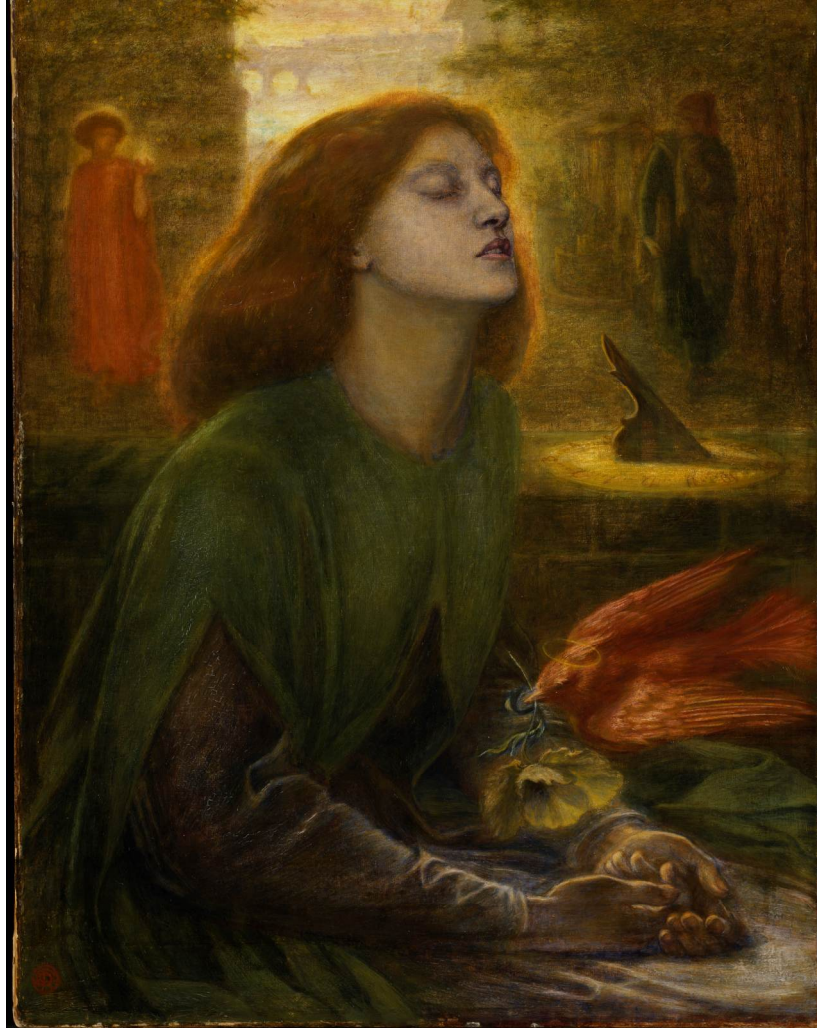

Fig. 1. *Beata Beatrix* by Dante Gabriel Rossetti. Copyright The Tate Gallery.

poem *Convivio* written 1303-1307.⁵ This work is a series of philosophical treatises and contains much medieval astronomy, as does also the *Divine Comedy*.^{6,7} Is this the earliest definition of equal and unequal hours?

Convivio, Treatise III Chapter VI

“Wherefore be it known that ‘hour’ is understood in two ways by the astronomers, one by making twenty-four hours of the day and night, to wit twelve of the day and twelve of the night, whether the day be long or short. And these hours are short or long in the day or in the night according as day or night waxes or wanes. And these hours the church uses when she says primes, tierce, sext and nones, and these are called the temporal hours. The other is to make day and night twenty-four hours, of which the day one while has fifteen hours and the night nine, and another while the night sixteen and the day eight, according as day or night waxes or wanes; and these are called equal hours. And ever at the equinox these, and those which are called temporal, are one and the same thing; because the day being equal to the night it must needs be.”

The answer to my question is that both systems were in use in Florence in 1290. In the Italian equal hours system the first hour of the day was about sunset, this has led to the date of the death of Beatrice being translated as the 9th, and sometimes 8th of June. One translation even allowed for the Gregorian calendar, which is pointless.

There seems little that can account for the belief that the shadow on the number nine of the sundial refers to the time of death of Beatrice. But the painting shows another story. The model for Beatrice was Lizzie Siddal, Rossetti's wife. The painting was started soon after they met but laid aside for several years on their 'falling out'. After her death in 1862 Rossetti was encouraged to work on it again as a memorial for Lizzie, and it was completed in 1866.

The bird and the poppy are not part of the Beatrice story; these Rossetti introduced to symbolise Lizzie's death. She is supposed to have kept a cage bird and the white poppy represents opium.

On the evening of her death, Rossetti and his friend Algernon Swinburne had been out and when Rossetti returned home Lizzie was in a coma from which she did not recover. She may have taken the overdose around 9pm, and that may have given Rossetti the opportunity to introduce his own 'nine' into the story, one on a more personal note. It was his own Beatrice who had died, his sad wife, Lizzie.

The Number Nine

What was the symbolism about the number nine that made Rossetti show the shadow in that position on his impossible sundials? Here are just two examples. I have already drawn attention to the early meetings of Dante and Beatrice, when they were both aged nine, and nine years later. Time and time again the number nine in some context or other appears in both poems, *La Vita Nuova* and the *Divine Comedy*. Here Dante describes their first meeting;⁸



Fig. 2. *Beata Beatrix*, study. D.G. Rossetti. Original in the Birmingham Museums and Art Gallery, available from <http://www.NINES.org>. 'The Rossetti Archive'.

"Nine times the heaven of light had revolved in its own movement since my birth and had almost returned to the same point when the woman whom my mind beholds in glory first appeared before my eyes...."

"She had lived in this world for the length of time in which the heaven of the fixed stars had circled one twelfth of a degree towards the East. Thus she had not long passed the beginning of her ninth year when she appeared to me and I was almost at the end of mine when I beheld her."

The sun had run its annual course nine times. The heaven of the fixed stars, the constellations, slowly shift eastward at one degree per 100 years, therefore one twelfth of a degree equals eight years and four months. They were both in their ninth years. And her death;

"Now according to the Arabian way of reckoning time, her most noble soul departed from us in the ninth hour of the ninth day of the month; according to the Syrian method, she died in the ninth month of the year, because the first month in that system is Tixryn the first, which we call October; and according to our way of reckoning, she departed this life in the year of our Christian era, that is of the years of Our Lord, in which the perfect number had been completed nine times in the century in which she had been placed in this world; for she was born a Christian of the thirteenth century."

The Sundial

The idea of the sundial was in Rossetti's mind at an early stage in planning the painting, but it seems he had never actually gone outside to look at one. A study for the painting shows an isosceles triangle or tripod arrangement for a gnomon, (Fig. 2) but I don't think the gnomon in the *Beata Beatrix* painting is too bad an effort, for the angle is about 48°, presumably for London rather than Florence; he must have finally looked at the real thing. The dial is a device to show the figure nine, but there are other ways Rossetti could have managed this. One study shows a clock, the hour hand at nine, but we must be thankful he stuck with the sundial, for his idea of a 13th-century clock is as odd as some of his sundials.

Nothing I have read has attempted to explain the symbolism of the sundial, but I will attempt an explanation. At the end of the *Divine Comedy*, Dante after journeying through the *Inferno* finally meets Beatrice again in the upper reaches of *Purgatorio*. She leads him into *Paradiso* and they are reunited in heaven. The last line of the *Divine Comedy* reads:

"L' amor che muove il sole e l'altre stelle"

and means 'the love which moves the sun and the other stars', a phrase which has appeared in one form or another over the past seven hundred years and nowadays reads, 'It's love that makes the world go round.'

I suggest that Rossetti's sundials mean that only by a sundial and its shadow can you see the world going round, and it is the only way to see what is happening in heaven.

ACKNOWLEDGEMENTS

Simone Bartolini for finding and providing the extract of *Convivio* in the original Italian, and to Dr J.P. Lester for helpful suggestions, also to John Davis for his usual valued help.

REFERENCES

1. D. Schneider: 'Ultima Nonna?', *Bull BSS*, 97.4, 5-7 (1997).
2. V. Surtees: *Dante Gabriel Rossetti. A Catalogue Raisonné*, (1971).
3. V. Surtees: *Ibid.*
4. John Davis and Simone Bartolini, personal communications.

5. J.M. Dent & Co.: *The Convivio of Dante Alighieri*, English translation (1903), from <http://www.archive.org>
6. M. Arnaldi: 'Da Buti, Dante and the Measure of Time', *Bull BSS*, 98.2, 14-16 (1998).
7. M. Arnaldi: 'Sundials painted in the Cloister of an Italian Monastery', *Bull BSS*, 98.1, 22-25 (1998).
8. Barbara Reynolds: *La Vita Nuova*, English translation, Penguin Books (1969).

APPENDIX

Complete List of Rossetti's Sundial Pictures

The pictures *Beata Beatrix*, *Danti's Amor* and *The Salvation of Beatrice* are all part of the Dante and Beatrice story. The *St Cecilia* pictures were produced to illustrate Moxon's edition of Tennyson's poem, *The Palace of Art*.

Any decent 'coffee table' book will have illustrations of the paintings. These and the studies can be found in Surtees' *Catalogue Raisonné*. On the internet see; <http://www.TheVictorianWeb.org> and *The Rossetti Archive* at <http://www.NINES.org> (NINES = Nineteenth Century Scholarship Online).

roger.bowling1@tesco.net

Title	Location	Comment
Beata Beatrix	Tate Gallery, London	
<i>ditto</i>	BMAG*	
<i>ditto</i>	Art Inst, Chicago	
<i>ditto</i>	BMAG	Two studies
Danti's Amor	Tate Gallery, London	Unfinished, no figs on dial
<i>ditto</i>	BMAG	Study, complete inc dial
<i>ditto</i>	BMAG	Study
The Salutation of Beatrix	Nat. Gallery Canada, Ottawa	
<i>ditto</i>	Fogg Mus of Art, Harvard	Study
<i>ditto</i>	BMAG	Rossetti's idea of a C13 clock
La Pia de Tolomei	U. of Kansas, Spencer Mus.	Scene from <i>Divine Comedy</i>
St Cecilia	BMAG	Pen & ink drawing
<i>ditto</i>	V&A, London	Woodcut

* BMAG: Birmingham Museums and Art Gallery

NEW DIALS (1)

Chelyabinsk, Russia

Near to Chelyabinsk in the Ural Mountains in a wooded area, Marina Krasnova, a very talented gardener, has created a small Japanese garden. I was asked to design a sundial to incorporate a tiger! Instead of an outline of a tiger, the Japanese character for a tiger was adapted to be a gnomon so that the long edge suits the latitude of Chelyabinsk (54°58' N, 60°25' E). The dial is in white marble and other Japanese characters at the hour markings give the current year of the tiger (2010), the year of birth of the mistress of this garden and members of her family. For the Japanese, the tiger is a symbol of energy, force and success, and protects the garden from thieves, fire and evil ghosts. And not least, this 'tiger' will frighten away any other animals that try to enter the garden.



Dracula Dial

I don't have a special interest in vampires or Dracula, but this well known story has inspired an unusual sundial. The dial has two names: 'The Last Day of Dracula' or 'Don't Eat After 6 am'. The dial plate is in red Armenian tuff with black plastic hour markers and the gnomon is made from stainless steel with a black lacquer, with assistance from Andrey Evdokov.

The dial was set up near to the ancient fortress of Korporie, not far from St Petersburg. Unfortunately the dial was stolen within 3 months, presumably by someone who is an admirer of Count Dracula.

Valery Dmitriev

THE EVOLUTION OF ENGLISH MASS & SCRATCH DIALS c.1250 – c.1650

Part 2. Age Ranking Dials by Type

CHRIS H.K. WILLIAMS

Part 1 established a methodologically coherent basis for dividing the database into three categories of scratch dial.¹ Here it will be shown that we can statistically discriminate between these dial types – they can be ranked by age and regional variations identified.

The obvious way to discern the past evolution of scratch dials is to analyse, examine and explain the relative frequency of dials by type. Whilst this is an obvious and (apparently) simple statement of intent, its actual execution is much less so. The reasons for this warrant exploration because they determine the precise technical specification, which some might find unexpected or counter-intuitive, of how the analysis must proceed – see Table 1. It can be seen that the weight of argument is overwhelmingly in favour of a cross-sectional approach to relative dial frequency.²

The key to age ranking dial types is the relationship between scratch dial frequency and loss. (Fig. 1) How can the ranking be inferred? The older the dials the greater the loss they will have suffered because of their longer exposure to church rebuilding and weathering. Although the extent of dial loss varies by county, it will still be the oldest dials

which are most responsive to varying conditions. In terms of Fig. 1, the older the dial type the steeper its gradient. The 360° dials, being significantly different from both other types,³ are the oldest surviving scratch dials. The 180° and 90° dials, being statistically indistinguishable, are of similar age.

Although dial loss is the primary explanation of dial frequency variability it is not a total one (Fig. 2). It explains most 360° dial variability, but less so others, especially 90° dials. Detailed probing of the data indicates that if a county tends to have more of a dial type it is offset by less of the others – thereby revealing variation between counties in the precise timing of their move away from 360° dials. Probing the data further it is apparent that, unlike other types, 90° dials were never, at a national level, fully or equally adopted.⁴ Finally there is a ‘to be explained’ element. The analysis excludes, given that no comparable data exists, scratch dial displacement by scientific dials and clocks. There can however be no doubting a progressive displacement occurred, culminating in the demise of the scratch dial era; its effects probably account for most of the ‘to be

Assessment Basis		Relative dial frequency defined as (1)	
Criterion	Comment	Serial	Cross-sectional
Objective.	Estimate age by dial type.	Reflects combined effect of age and the duration a dial type remained in use. (Is the least common dial type the oldest or that in use for the shortest time?)	Accepting each dial type was in use for much the same time across the country, this measure primarily reflects the influence of age.
Reliability of estimates.	Dial type data under-represents older dials because only the categorisable recorded subset of the database is included. It per force excludes (the presumed older) uncategorisable or unrecorded dials. (2)	Because inter dial types are compared, there is an unknown element of bias to this measure and the results of its analysis.	Because only intra dial type comparisons are made, no bias is imparted to this measure or the results of its analysis.
Compatibility.	Can previous results be used in this analysis? Can the results of this analysis be combined with previous results? (3)	No. Previous results are incompatible with this analysis and its results.	Yes, all results can be combined. On this measure results are unaffected by representational differences between all listed dials and the categorisable recorded subset.

Table 1. Considerations determining the technical specification of scratch dial frequency by type analysis.

Notes:

1. Two alternatives present themselves when considering the relative frequency of a dial type in a county. The serial, relating the frequency to that of other dial types in the county: And the cross-sectional, relating the frequency to that of the same dial type in the country as a whole. Their crucial differentiating factor is that

the serial is an inter, whilst the cross-sectional is an intra, dial type comparison.

2. For the (subset) composition of the scratch dial database (all listed dials) see main note 1 reference.
3. For previous results (based on all listed dials) relating to dial loss, dial redundancy and 1650 dials/church see main note 6 references.

explained' element – the increase therein for the later dial types is consistent with such a presumption.⁵

Cross-sectional analysis permits an age ranking and sequencing of dial types. If, however, the cross-sectional results are pooled with those of the life cycle model (LCM),⁶ the transition from 360° dials can be dated. It has already been established that the benchmark group of counties (a quarter of the total) have lost two-thirds of their 1650 scratch dials.⁷ It can be seen from Fig. 1 however that 360° dials are about twice as sensitive to loss as other dial types. It can thus be inferred that since 1650 some five out of six of the 360° dials, but only about half of the other types of dial, have been lost. It can be further inferred that the composition of the 2-3 scratch dials per church in 1650 was 60:40 in favour of 360° dials versus the rest. This predominance of 360° dials at the end of the scratch dial era implies that the adoption of alternative types must have been comparatively late: 1500 is the date most consistent with LCM parameters. Some of the implications of these findings merit highlighting via further exploration and elaboration.

Firstly, the 1650 split between 360° and other dials demonstrates how utterly misleading naively taking the surviving 35:65 ratio⁸ at face value is. We can now appreciate this is because differing dial age results in a differential post-1650 loss. If allowance is also made for pre-1650 dial loss, it is clear the vast majority of scratch dials made in the evidential period must have been of the 360° type.

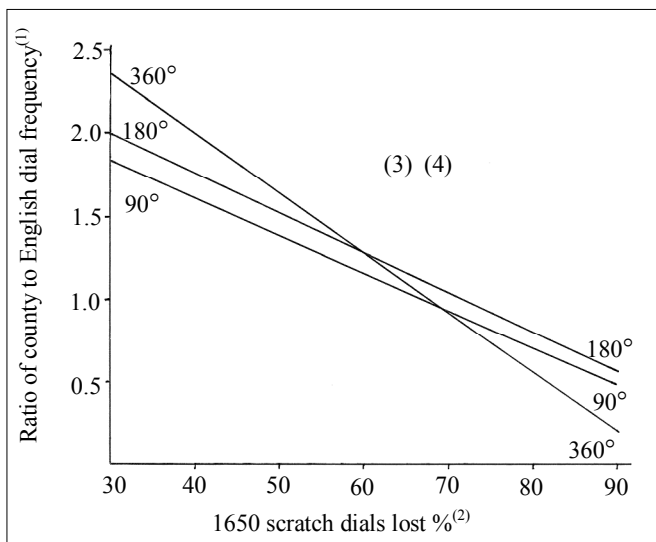

Fig. 1. Relationship between cross-sectional scratch dial frequency and dial loss.

Notes:

1. For each dial type, each county's dials/medieval church is divided by the English average dials/medieval church for that dial type. (See Table 1 for choice of specification).
2. As estimated in main note 7 reference.
3. Each dial type's line estimated by standard least squares regression.
4. As a county's proportion of 1650 scratch dials lost increases, so the incidence of its dials declines – hence the downward sloping lines.

Secondly, some might be surprised by the implication that in 1650 there was (on average) just a single 180° or 90° dial per church: is that credible? The LCM validates it. By about 1650 the progressive displacement of scratch dials by scientific dials and clocks was complete. Those churches where displacement occurred before 1500 would never have had any 180° or 90° dials: whilst for those where displacement occurred after 1500, the subsequent accumulation of such dials (through redundancy) would have been truncated. There would also have been some loss of such dials before 1650. In combination these factors render their apparently low average incidence explicable; it is not inconsistent with multiple 180° and/or 90° dials in the (minority of) churches where scratch dials were yet to be displaced.

Thirdly, how can we be sure 360° dials fell out of use around 1500? This can perhaps be most readily appreciated through the following considerations. The nature of the LCM is such that the data becomes markedly inconsistent with any materially different alternative dating assumption. This arises because whilst the total incidence of scratch dials remains unchanged, the 'presumed' split between 360° and other dials changes sharply as they are 'substituted' one for one.⁹ As a consequence, any radical alternative view on the timing of the cessation of 360° dial use 'requires' an implausible set of large differential revisions to LCM parameter estimates – it is not merely a matter of a slightly variant interpretation of existing results.

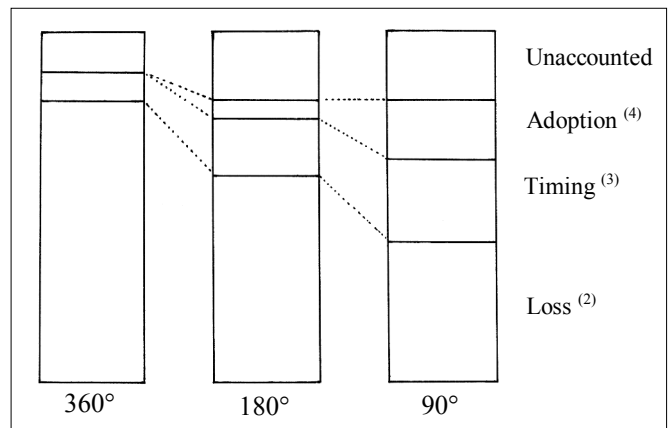

Fig. 2. Accounting for the variability of cross-sectional scratch dial frequency.¹

Notes:

1. The proportion of the sum of the squared deviations accounted for by (variations in) individual factors.
2. The influence of (variations in) loss is measured by the coefficient of determination of Fig. 1 regressions.
3. The influence of variability in the timing of the move away from 360° dials is calculated from the negative correlation structure within the residuals matrices of Fig. 1 regressions.
4. The partial (variable by county) adoption of 90° dials is indicated by the excess of their residuals, compared to 180° dials, in the Fig. 1 regressions. As the two dial types were 'substitutable' (with negative correlation between their residuals) it accounts for variability in both.
5. That proportion of variation not accounted for by elements (2), (3) and (4).

Where does this paper leave us? It has established that, contrary to the profile of surviving dials, most evidential period scratch dials were of the 360° type. Their use ended, in favour of the 180° and 90° types, around 1500. Adoption of the 90° dials varied markedly on a regional basis. This pattern of scratch dial evolution is entirely empirical – echoing the combined collective message of thousands of listed dials – and the first to be derived on a scientific basis. That said, it must also be noted what it is not. It is not the evolution of scratch dials' actual in-use painted and decorated appearance; instead we have a partial, skeletal, monochrome guide thereto. Also, it is only a descriptive contribution to our understanding of scratch dial evolution; it is not an explanation of why. Further elucidation calls for additional alternative lines of investigation.

REFERENCES & NOTES

1. Chris H.K. Williams: 'The Evolution of English Mass & Scratch Dials c.1250 – c.1650. Part 1 Dial Categorisation', *Bull BSS*, 22(iii), 22-24, (2010). This article continues the

- definitional nomenclature developed in Part 1.
2. For the complete avoidance of doubt, for the reasons embedded in Table 1, comparison of the (surviving) frequency of one dial type relative to another, however intuitively appealing, is completely misguided.
3. Standard statistical hypothesis tests at the 5% level of significance.
4. The regional variation in the timing of the cessation of 360° dial use and the extent of 90° dial adoption will be outlined and considered further in subsequent articles.
5. Scratch dial displacement will be considered in a subsequent article.
6. See Chris H.K. Williams: 'The English Scratch & Mass Dial Era: The Evidential Period c.1250 to c.1650', *Bull BSS*, 21(iv), 18-19, (2009) and references therein.
7. See Chris H.K. Williams: 'The Prevalence of English Scratch (Mass) Dials c.1650 – Part 2', *Bull BSS*, 21(iii), 34-35, (2009) for derivation and listing of counties.
8. Ref. 1, Fig. 2.
9. It follows that the regional variations in the timing of the move away from 360° dials referred to earlier are not large.

chkwilliams@googlemail.com

NEW DIALS (2)

Highlands School, North Vancouver, Canada

Walk-on sundials do not usually have the analemma '8' shape on the dial itself. It has been recognised that a single analemma shape will yield errors if used directly. This was the cause of the mysterious error in the early Brou dial in France.^{1,2}

It is impossible to provide direct mean time correction over the whole dial using one analemma because the vector correction for the EoT is of opposite signs in the morning and afternoon. It is possible to obtain a direct reading of close to mean time using one analemma for the morning and another for the afternoon. However, perfect values can be obtained for only two selected times in the morning and two in the afternoon. There will be errors at all other times: the problem of determining the least error point can be dealt with analytically^{1,2} or by iteration.³ Helmut Sonderegger's 'Alemma' software⁴ uses Seidelman's method with a minor addition which allows the arbitrary distribution of accuracy over selected portions of the day.

This dial for the Highlands school, North Vancouver was designed using 'Alemma' and built by parent volunteers. It has an average absolute error of 31 seconds and a maximum error of about 3 minutes. These are well inside the reading error. The double analemma design takes only a little more effort than a normal analemmatic dial and, as well as providing mean time directly, the decorative value



adds visual interest and provokes curiosity. The zodiac signs are arranged in approximately the correct positions around the dial.

The dial was set out using vector bars based on the dial centre and the maximum value of the semi-minor axis. Plywood jigs were made for the analemmas. All the setting out equipment was designed to accept a 'Hilti 14' concrete drill with a special tool to drill countersunk holes for bronze survey markers. The survey markers were embossed with the location using an old 20 ton jack and grouted into the asphalt with bitumen grout. The markers provide a permanent reference for future painting. A heavy oil-based paint was used with home-made stencils for each feature.

REFERENCES

1. F.W. Sawyer: 'Of Analemmas, Mean Time and the Analemmatic Sundial - Pt 1', *Bull BSS*, 94(2), 2-6 (Jun 1994).
2. F.W. Sawyer: 'Of Analemmas, Mean Time and the Analemmatic Sundial - Pt 2', *Bull BSS*, 95(1), 39-44 (Feb 1995).
3. P.K. Seidelman: 'A Design for an Analemmatic Standard-Time Sundial', *Sky and Telescope*, 50(6), 368-369 (December 1975).
4. The Alemma program can be downloaded from <http://web.utanet.at/sondereh>

Brian Albinson
brianalbinson@shaw.ca



THE BSS 2010 SUNDIAL DESIGN COMPETITION

TONY BELK

This was the fourth competition in a series which started in 1995 under the title ‘Open Awards Scheme’, and is aimed at encouraging the production of high quality dials. There were 14 entries covering a wide range of types and purposes from England, Scotland and Wales. This was only half the number received in 2005.¹ In addition to horizontal, vertical, equinoctial, polar and spherical dials we also had a moon dial, a hemi-cyclic dial and one which sounded an alarm at a time set. Apart from celebrating individual lives, one dial celebrated a garden and another an author. Perhaps the most appropriate sundial inscription was attributed to Einstein “Make things as simple as possible, but not simpler”. The judges (Douglas Bateman, Frank Evans, Jackie Jones and Geoff Parsons) met a number of interesting people in their travels, with a wide variety of different views on the value and significance of sundials.

Three Restoration, seven Professional and four Amateur entries seemed a reasonable spread but unfortunately there were no Junior entries. We need as a Society to continue to try to find some means of encouraging and assisting schools to take part in such activities. The entries are tabulated below.

Prizes for Restoration Designers

First Prize	G Aldred (Entry 11)	Fig. 1
Highly Commended	H James (Entry 1)	Fig. 3

Prizes for Professional Designers

Highly Commended	H James (Entry 4)	Fig. 4
Highly Commended	A Hunter (Entry 7)	Fig. 5

Prizes for Amateur Designers

First Prize	C Pile (Entry 6)	Fig. 2
Highly Commended	A James (Entry 14)	Fig. 6

The judges are able to award a Major Prize and we felt that G. Aldred’s restoration project had been so demanding, so well researched, manufactured, installed and that it fitted so well with its surroundings that he should receive this prize.

MAJOR PRIZE

Restoration class: Graham Aldred

This restoration, sponsored by the National Trust, includes many aspects of dialling interest. See also the rear cover and Ref. 2 for more details. Based on a 1904 photograph



Fig.1. Restoration, Graham Aldred, Major Award.

and a very badly corroded dial plate, the historical forensic work was very demanding and led to an original date of 1683. A new dial plate replicating the original in as much detail as could be discerned was delineated and made. Unusually there was an equatorial device added on the north side of the original gnomon and this has been reproduced in the restored dial, based on a 1904 photograph. The Legh family crest is included and with the extant pedestal dating from 1725 the dial makes a most pleasing addition to the Orangery Terrace. 1683 was a time of considerable scientific activity and it is likely that the original Lyme Park dial played a part in the development of our understanding of gnomonics.



Fig. 2. Amateur, Christopher Pile, First Prize.

FIRST PRIZE WINNER

Amateur class: Chris Pile

This is a very interesting south facing vertical dial combined with a polar noon analemma, made inventively from a wide variety of easily available and cheap materials (Fig. 2). It is impressive to view and blends in very well with its surroundings. Every aspect of this dial has been well thought out with excellent and detailed plans to ensure accurate delineation. Noon is indicated with a light spot and there are profiles on the gnomon showing 5, 10, 20 and 30 minutes on either side of noon. GMT noon is read from the analemma with Greenwich noon and local noon also displayed.

HIGHLY COMMENDED PRIZES

Restoration class: Harriet James

A very good restoration that gives a fine dial even more life (Fig. 3). The new gnomon shape has been ‘researched’



D Bateman

Fig. 3. Restoration, Harriet James, Highly Commended.

to ensure that it is correct for the period of the dial. The patination has been well done to age it to match the dial. The late 18th-century dial plate, installed in its present site in 1847, has been sympathetically cleaned to bring back some of its legibility. It is a very pleasing addition to a most colourful public park.

Professional class: Harriet James

Moon dials are unusual and this horizontal sun/moon dial has a dial plate of pure white marble with separate sun and moon scales (Fig. 4). The stainless steel gnomon is supported by a crescent moon. The pedestal of Portland stone is decorated with scaphe images of the moon’s phases. The delineations for sun and moon time are very clear and there is a table of approximate transit times which is needed to obtain the moon time.



Fig. 4. Professional, Harriet James, Highly Commended.

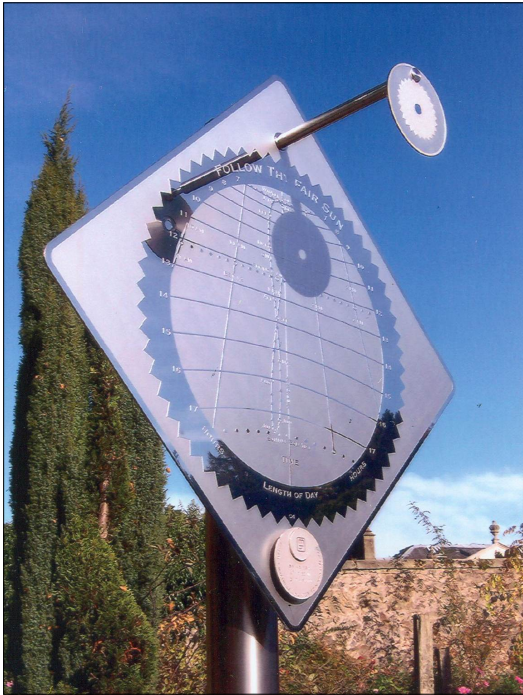

Fig. 5. Professional, Alastair Hunter, Highly Commended.

A Hunter

Professional class: Alastair Hunter

This dial (Fig. 5) is the prototype for an intended commercial series. It has fine engineering qualities and provision is made for its accurate installation. It is a diamond plate of stainless steel, mounted on a metal pole. With its eye-hole gnomon it reads from 10 am to 2 pm. Its main virtue lies in its precision and in the addition of numerous subsidiary functions of interest including a noon analemma, day length and equinoctial and solstitial indicators. There is a plaque explaining its use to the public.

Amateur class: Andrew James

This attractive vertical dial in slate makes use of a 'super ellipse' for the curved lines for the time markers. This is attractive and allows good use of the space for the all the lettering. The gnomon has a very unusual 'sundial' feature in that the underside of part of the gnomon is shaped to be



Fig. 7. Spherical dial by Tim Chalk with the quote attributed to Einstein.



Fig. 8. Equatorial dial by Heiner Thiessen which sounds an alarm at the time set.



A James

Fig. 6. Amateur, Andrew James, Highly Commended.



D Bateman

Fig. 9. Horizontal dial by Lawrence Brewer commemorating E.M. Forster with high quality engraving on the gnomon.

Number	Class	Maker	Type	Owner	Location
1	Restoration	H James	Horizontal	Leamington	Leamington
8	Restoration	D Kay	Vertical	Carlisle CC	Carlisle
11	Restoration	G Aldred	Horizontal	NT	Lyme Park
2	Professional	H James	Polar	P Bristow	Bicester
3	Professional	S Higgon	Hemi-cyclic	J Gleave	Montgomery
4	Professional	H James	Horizontal	P Bristow	Bicester
5	Professional	T Chalk	Spherical	A Macfarlane	Cambridge
7	Professional	A Hunter	Noon mark	Scottish NT	Glasgow
9	Professional	P Nicholson	Horizontal	B Piper	Putney
10	Professional	P Nicholson	Equatorial	P Kingsley	Welshpool
6	Amateur	C Pile	Multiple	C Pile	Winchester
12	Amateur	L Brewer	Horizontal	L Brewer	Pershore
13	Amateur	H Thiessen	Equatorial	H Thiessen	Petersfield
14	Amateur	A L James	Vertical	A L James	Burnham on Sea

The 2010 BSS Sundial Design Competition Entry List

an ‘inverse half analemma’ so that the dial can give mean time at noon, winter to summer, and at 3 pm, summer to winter, against set markers. The dial celebrates a garden and the furniture reflects this well.

Other Dials

Apart from the prize winners there were a number of other attractive and interesting dials. Illustrated here are the quotation attributed to Einstein on dial 5 shown in Fig. 7; dial 13 which sounds an alarm Fig. 8 (see Ref. 3); and dial 12, commemorating E.M. Forster, with a gnomon covered in high quality engraving in Fig. 9.

CONCLUSION

The overall requirement of the competition was that the dials should encourage the design and manufacture of new dials. This involved accuracy of delineation, suitability for its environment, quality of workmanship, aesthetic quality, creativity and a clear written explanation for public dials. We also looked to see whether there was any simple modification that would have improved the dial’s performance.

The standard of design and workmanship was good, and almost all entrants had received good advice from a sundial expert. We hope that in five years time the economic clouds will have lifted and more entries will be forthcoming.

THANKS

I would like to thank my fellow judges Jackie, Douglas, Frank and Geoff, for their enthusiastic participation in the judging and for so readily making themselves available for our visits and meetings. I found it an interesting and enjoyable activity which gave me some new understandings of the design, use and value of sundials. I am even inspired to try to make an entry myself in the next



Dial 3, S. Higgon



Dial 9, P Nicholson



Dial 8, D Kay



Dial 10, P Nicholson

competition. I would also like to thank the entrants for producing such interesting dials, for submitting all the required information and for hosting the judges on our various visits.

REFERENCES

1. N. Nichols: *Bull BSS*, 17(iii), 113 (2005).
2. G. Aldred: ‘The Lyme Hall Horizontal Equinoctial Sundial’, *BSS Bull*, 17(iv), 160-168 (2005).
3. H. Thiessen: ‘A Chime Dial’, *BSS Bull*, 22(ii), 36 (2010) and T. Moss: ‘Building the Chime Dial’, 22(ii), 37 (2010).

CHAIRMAN’S THANKS

The successful conclusion of another BSS design competition owes much to Tony Belk, the organiser, who co-ordinated the event, with the assistance of his judges. His report reflects a job well done and he and his team are to be congratulated – with the warmest thanks of Council.

Christopher St J.H. Daniel

HONORARY OFFICIALS OF THE BRITISH SUNDIAL SOCIETY

Patron: The Hon. Sir Mark Lennox-Boyd

President: Sir Francis Graham-Smith F.R.S.

Vice-Presidents: Mr David A Young & Mr Frederick W Sawyer III

COUNCIL MEMBERS

Mr C St J H Daniel
8 The Maltings
Abbey Street
FAVERSHAM
Kent ME13 7DU
(Chairman)
Tel: 01795 531804
chrisdaniel180@btinternet.com

Mr G Aldred
4 Sheardhall Avenue
DISLEY
Cheshire, SK12 2DE
(Secretary, Librarian and
Restoration)
Tel: 01663 762415
graham@sheardhall.co.uk

Dr John Davis
Orchard View,
Tye Lane
FLOWTON
Suffolk IP8 4LD
(Editor)
Tel: 01473 658646
john.davis51@btopenworld.com

Mr J Foad
Greenfields
Crumps Lane
ULCOMBE
Kent, ME17 1EX
(Registrar)
Tel: 01622 858853
Register.BSS@keme.co.uk

Ms Jackie Jones
51 Upper Lewes Rd
BRIGHTON
East Sussex
BN2 3FH
(Membership Secretary)
Tel: 01273 673511
jackie@waitrose.com

Mr G Stapleton
50 Woodberry Avenue
NORTH HARROW
Middlesex
HA2 6AX
(Treasurer)
Tel: 020 8863 3281
manaeus2000@yahoo.co.uk

Mr R C Mallett
21 Cantilupe Close
Eaton Bray
DUNSTABLE
Beds., LU6 2EA
(Webmaster)
Tel: 01525 222215
100114.573@compuserve.com

Mr P Powers
16 Moreton Avenue
HARPENDEN
Herts., AL5 2ET
(Conferences)
Tel: 01582 713721
patrick_powers@dunelm.org.uk

Mr M Cowham
PO Box 970
Haslingfield
CAMBRIDGE
CB23 1FL

Miss R J Wilson
Hart Croft
14 Pear Tree Close
CHIPPING CAMPDEN
Gloucs., GL55 6DB

Mrs E Hill
4 The Village
Stonegate
Nr WADHURST
East Sussex, TN5 7EN

Mr David A Young
Brook Cottage
112 Whitehall Rd
CHINGFORD
London, E4 6DW

Mr Ian Butson
60 Churnwood Rd
Parsons Heath
COLCHESTER
Essex, CO4 3EY

Mr A O Wood
5 Leacey Court
CHURCHDOWN
Gloucester, GL3 1LA

Mr J M Shaw
3 Millwood
Higher Bebington
WIRRAL
CH63 8RQ

Mr D Pawley
8 Rosemary Terrace
Enborne Place
NEWBURY
Berks., RG14 6BB

SPECIALISTS

(Advertising)
Tel: 01223 262684
ads@brownsover.orangehome.co.uk

(Biographical Projects)
Tel: 01386 841007
jill.wilson@ukonline.co.uk

(Sales)
Tel: 01580 201720
Elsbeth@ehill80.fsnet.co.uk

(Acting Archivist)
Tel: 020 8529 4880
davidyoung@essexcongress.org.uk

(Photographic Competition)
Tel: 01206 860 724
ian@tipsdial.orangehome.co.uk

(Mass Dials)
Tel: 01452 712953
aowood@soft-data.net

(Newsletter Editor)
Tel: 0151 608 8610
jmikeshaw@ntlworld.com

(Newbury Meeting Organiser)
Tel: 01635 33519
info@towertime.co.uk

The British Sundial Society
c/o The Royal Astronomical Society
Burlington House
Piccadilly
London, W1J 0BQ

The Society's website is at www.sundialsoc.org.uk
The British Sundial Society is Registered Charity No. 1032530

